

CA1

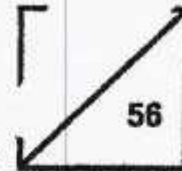

Rosyth School
Diagnostic Assessment 2021
STANDARD SCIENCE
Primary 6

Total
Marks:



Name: _____

Class: Pr 6-_____ Register No. _____

Duration: Total time for Booklets A and B: 1 h 45 min

Date: 25 February 2021

Parent's Signature: _____

Booklet A

Instructions to Pupils:

1. Do not open the booklet until you are told to do so.
2. Follow all instructions carefully.
3. This paper consists of 2 booklets, Booklet A and Booklet B.
4. For questions 1 to 28 in Booklet A, shade the correct ovals on the Optical Answer Sheet (OAS) provided using a 2B pencil.

This booklet consists of 22 printed pages (including cover page).

This paper is not a weighted assessment. The purpose of this diagnostic assessment is to monitor your learning and to provide feedback.

This paper is not to be reproduced in part or whole without the permission of the Principal.

[The page contains extremely faint, illegible text, likely bleed-through from the reverse side of the document. The text is too light to transcribe accurately.]

For each question from 1 to 28, four options are given. One of them is the correct answer. Make your choice (1, 2, 3 or 4). Write the correct answer in the OAS provided.

(56 Marks)

1 Inhaled air has _____ than exhaled air.

- (1) less oxygen
- (2) more nitrogen
- (3) less water vapour
- (4) more carbon dioxide

2 Study the digestive system in human as shown below.

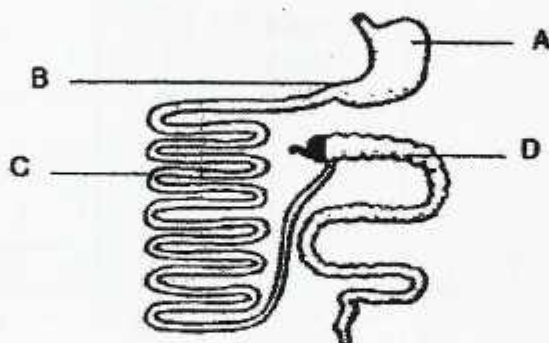

In which part of the system is digestion completed?

- (1) A
- (2) B
- (3) C
- (4) D

3 The diagram below shows the flow of blood in the human body.

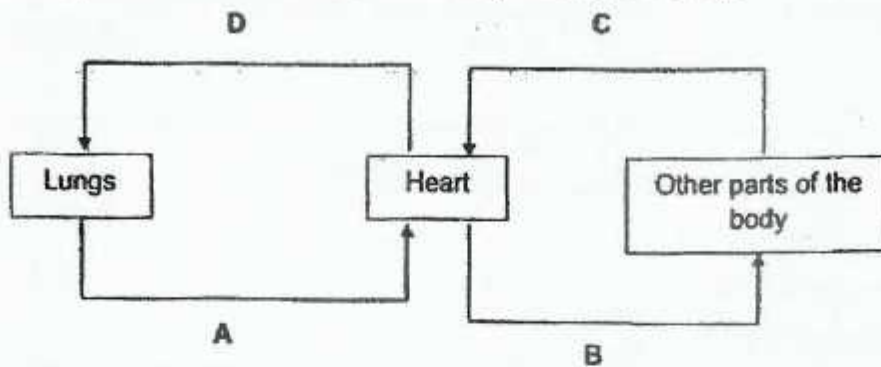

Same amount of blood were taken from A, B, C and D and the amount of carbon dioxide in the blood was compared. Which one of the following graph is correct?

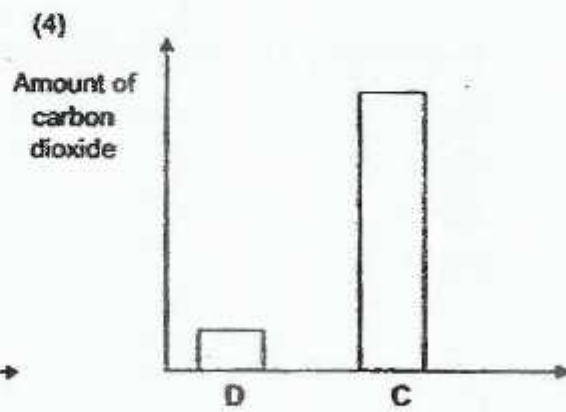
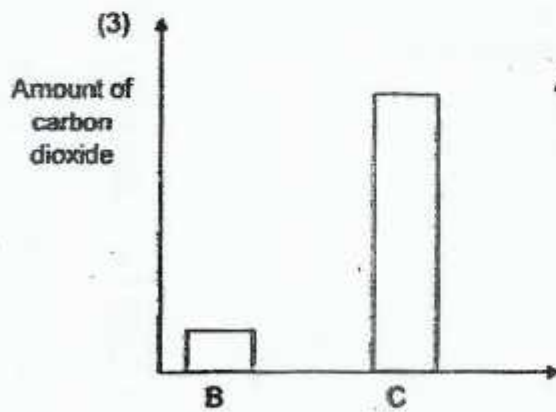
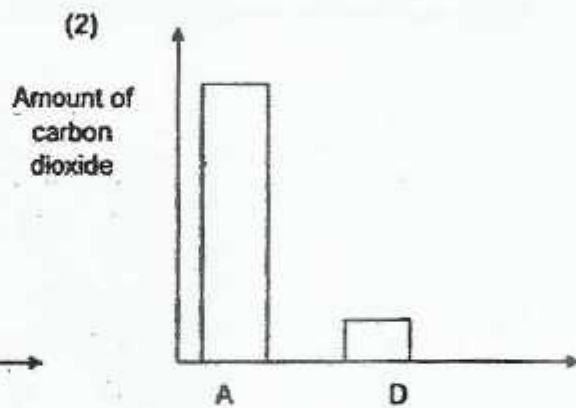
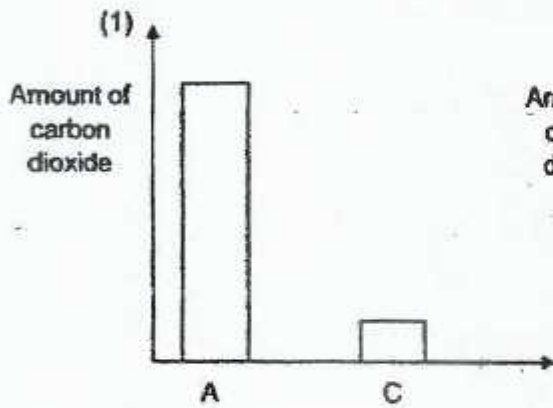

- 4 The graph below shows how gases are transported in the blood through blood vessels A, B, C, D, E, F and G in the circulatory systems of a fish and man.

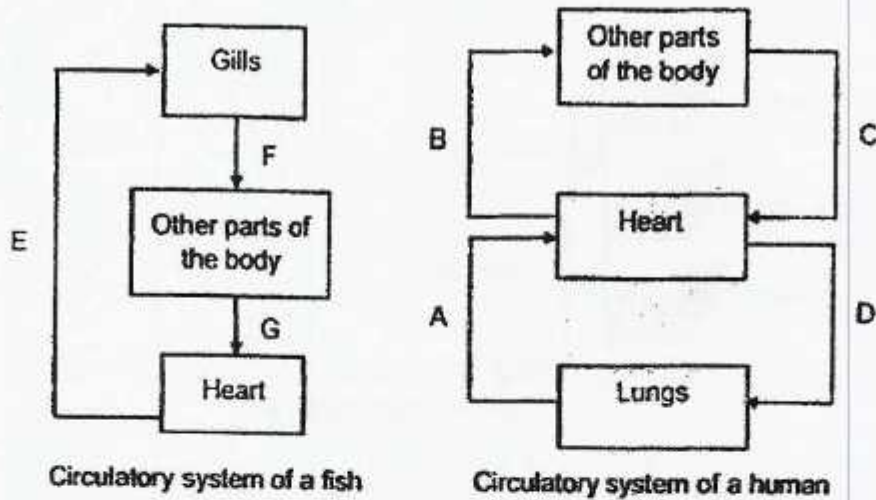

Based on the diagrams above, which of the following statement is correct?

- (1) Blood vessels A and G carry blood rich in oxygen.
- (2) Blood vessels B and E carry blood rich in oxygen.
- (3) Blood vessels C and F carry blood rich in carbon dioxide.
- (4) Blood vessels D and E carry blood rich in carbon dioxide.

- 5 Adeline cut out different parts of the stem of a plant and left it in the garden as shown in the diagram below. She watered the plant daily.

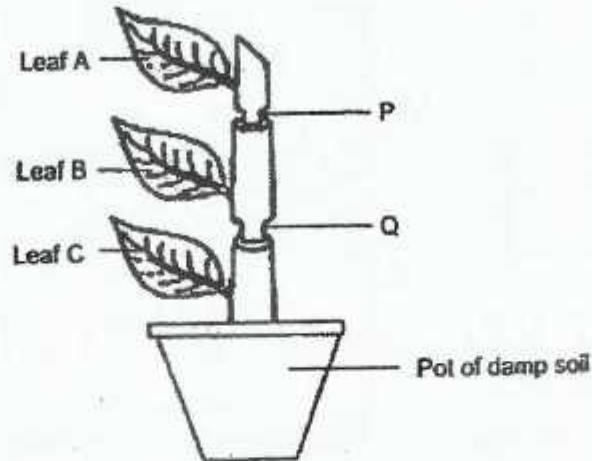

She observed that Leaf A wilted and Leaf B and Leaf C were green after a few days. Which tube/s were removed at P and Q when different parts of the stem were cut?

	P	Q
(1)	Food carrying tubes only	Food-carrying tubes only
(2)	Food carrying and water carrying tubes	Food carrying tubes only
(3)	Food carrying and water carrying tubes	Water carrying tubes only
(4)	Food carrying tubes only	Food carrying and water carrying tubes

- 6 Jessica chose three similar plants, A, B and C, for an experiment. She trimmed off all the leaves from plant A and a few leaves from plant C. She also cut off the roots of all three plants and placed each plant into a beaker containing red-coloured water with a layer of oil at the top.

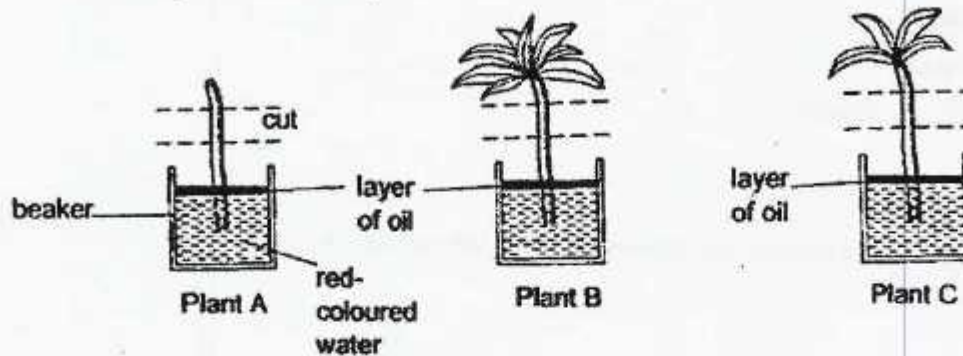

She cut across the stems after 30 minutes as shown in diagram above and observed if there were red stains at the cross-section.

Which one of the following questions was Jessica trying to investigate through this experiment?

- (1) Do plants need roots to absorb water?
 - (2) Do plants need leaves to absorb water?
 - (3) Does the number of leaves affect the amount of water taken in?
 - (4) Does the number of leaves affect how fast water travels up the stem?
- 7 Which of the following is a direct source of energy for man?
- (1) Air
 - (2) Sun
 - (3) Food
 - (4) Water

8 Which one of the following is produced during photosynthesis?

- (1) Water
- (2) Starch
- (3) Oxygen
- (4) Carbon dioxide

9 Amanda carried out an investigation using the set-ups as shown below.

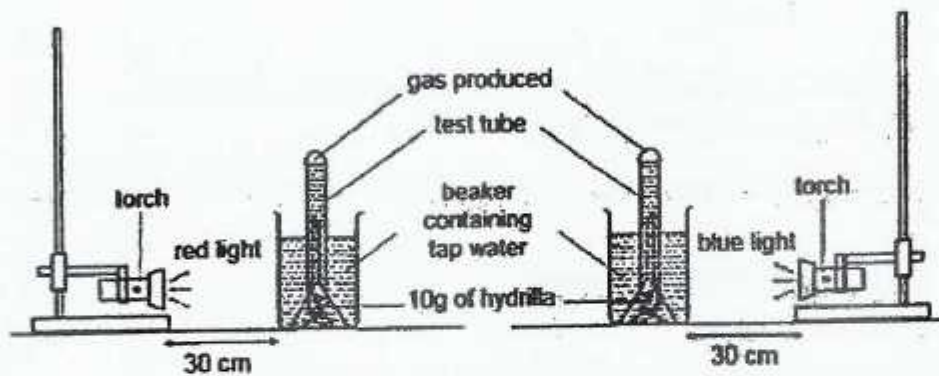

To ensure a fair test, Amanda kept the distance between the torch and hydrilla the same.
What could she change in the above set-up to increase the amount of gas produced?

- (1) Use pond water.
- (2) Use green light.
- (3) Use 20g of hydrilla.
- (4) Use bigger beakers.

- 10 The table below shows the amount of energy needed and the breathing rate for different activities, A, B, C and D.

Activity	Amount of energy needed for one minute of activity (kJ)	Breathing rate (Number of inhalations per minute)
A	130	50
B	30	20
C	280	40
D	300	80

Which activity does not support the hypothesis: "the greater the intensity of activity, the greater the amount of oxygen needed by the body"

- (1) A
- (2) B
- (3) C
- (4) D

- 11 A shadow is formed because _____.

A: light can be blocked
B: light can be reflected
C: light can be absorbed

- (1) A only
- (2) C only
- (3) A and B only
- (4) A, B and C

- 12 In the diagram below, Jonny was standing behind a piece of cloth. He was not able to see the table.

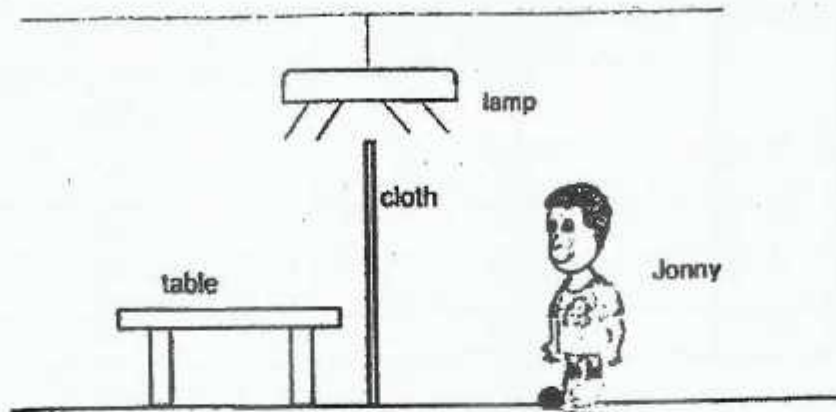

Which one of the following explains why Jonny was not able to see the table?

- (1) The table is not a light source.
- (2) The table did not reflect light from the lamp.
- (3) The cloth did not allow light to pass through.
- (4) The light from the lamp did not fall on the table.

- 13 A torchlight and a ball were placed as shown below to cast shadow on a screen.

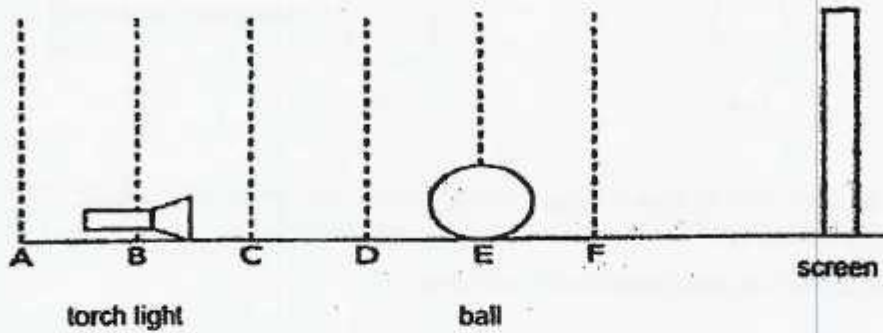

Which of the following shows the position of the torchlight and ball such that a smallest shadow will be cast on the screen?

	Position of torchlight	Position of ball
(1)	A	E
(2)	D	E
(3)	B	D
(4)	B	F

- 14 Joshua conducted an experiment using a ball and ring apparatus as shown below.



ball



ring

The ball was able to pass through the ring at room temperature. However, after heating the ball for a while, it was unable to pass through the ring.

Which of the following explains this observation?

	The ball	The ring
(1)	expanded	contracted
(2)	expanded	remained the same
(3)	remained the same	expanded
(4)	remained the same	contracted

- 15 Four copper rods, A, B, C and D, of different sizes, as shown below, were heated to 200°C.

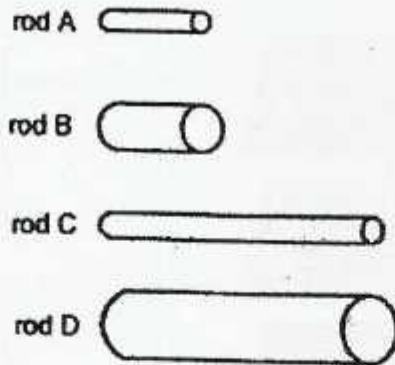

Which one of the following statements is correct about the heat transfer?

- (1) Heat will be transferred between rods, C and D, when they are placed together.
- (2) No heat will be transferred between rods B and C, when they are placed together.
- (3) Some heat will be transferred between rods D to A, when they are placed together.
- (4) All rods would have transferred the same amount of heat to the surrounding air to reach room temperature.

- 16 David used two dishes which were kept in a room overnight. He placed a piece of identical ice on each dish and observed the two pieces of ice melting for two minutes in that room.

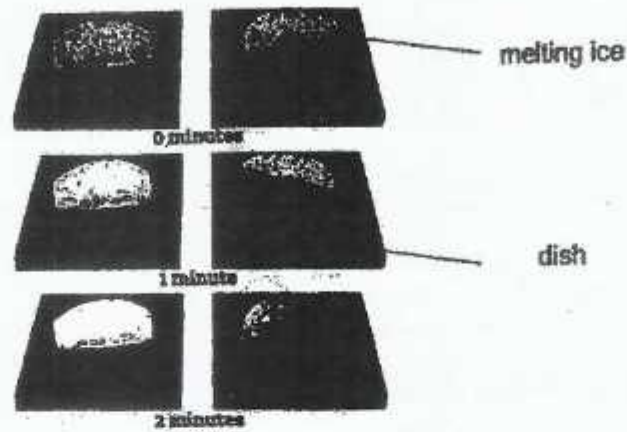

What could be the possible reason for the observation above?

- (1) Ice melts at different temperatures.
- (2) Ice melts at the same temperature.
- (3) The two dishes are at different temperatures.
- (4) The two dishes are made of different materials.

- 17 Steve placed steel container L into steel container K, both initially at room temperature. He then poured 100 cm^3 of water at 10°C into container K and 100 cm^3 of water at 90°C into container L.

The temperatures of water in K and L were recorded for over three hours.

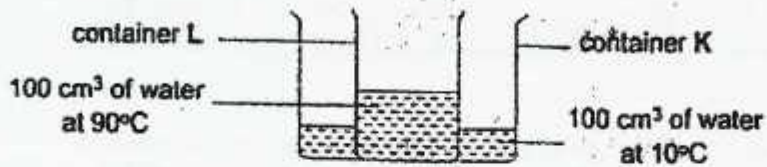

Which one of the following is the correct graph for his results?

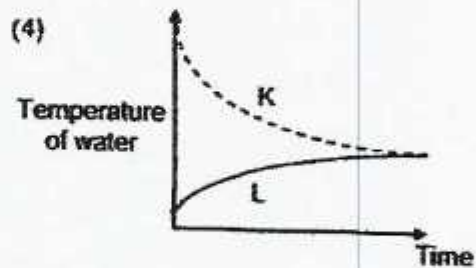
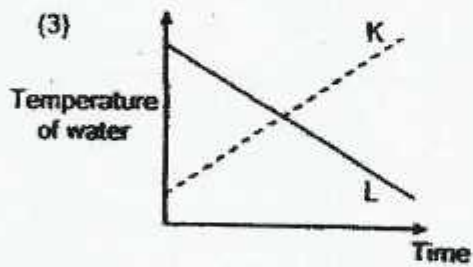
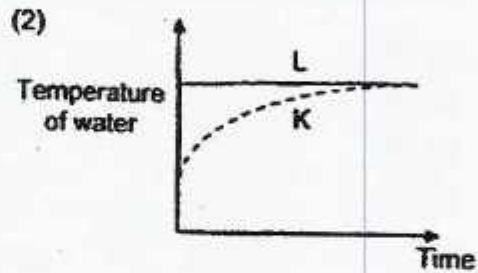
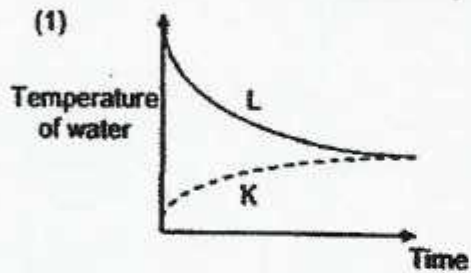

- 18 Study the four set-ups W, X, Y and Z below carefully. An egg was placed into each set-up at the same time.

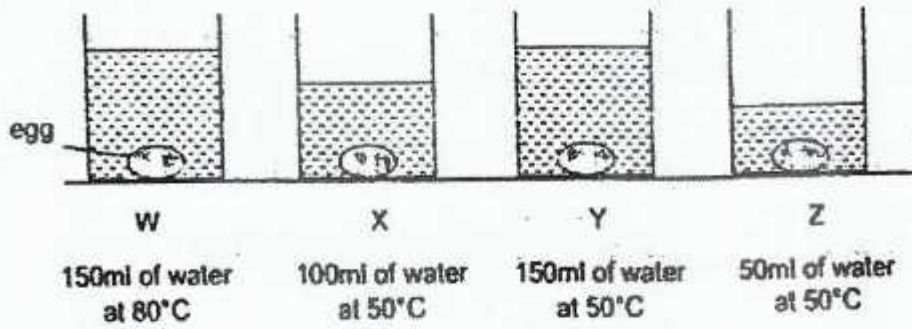

In which set-up, the egg would be cooked the fastest?

- (1) W
- (2) X
- (3) Y
- (4) Z

- 19 A metal ball hangs on a string fixed at point P. It starts from position X and swings to the furthest position on the opposite side, position Y. It then swings to and fro several times before stopping at position Z.

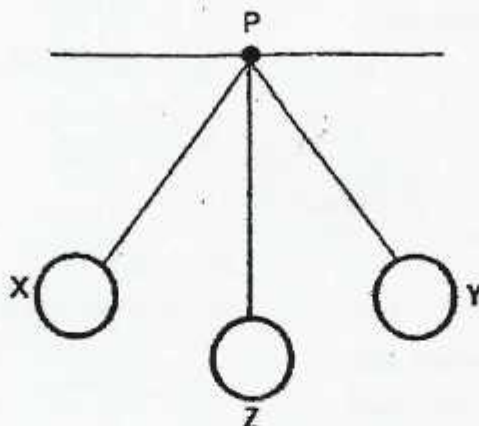

- When does the ball have the most kinetic energy?
- (1) The last time at position X
 - (2) The first time at position Y
 - (3) The first time at position Z
 - (4) The last time at position Z
- 20 Which one of the following is not an example of energy conversion?
- (1) Walking up a staircase
 - (2) Cooling hot water in a cup
 - (3) Lighting a candle using a matchstick
 - (4) Generating electricity in a power station

- 21 Ravi made a toy as shown below. When he turned the plastic roller, the toy would move forward on the floor.

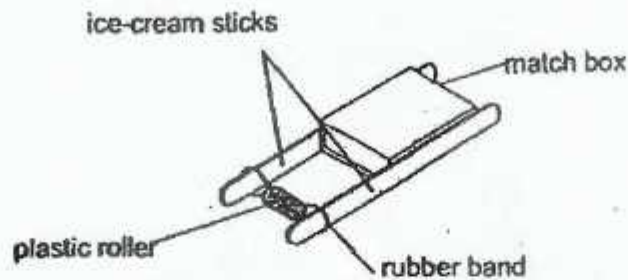

What should Ravi do if he wanted the toy to travel a further distance?

- (1) Use a shorter ice-cream stick.
 - (2) Use a thicker ice-cream stick.
 - (3) Increase the size of the match box.
 - (4) Increase the number of turns on the plastic roller.
- 22 The diagram below shows an energy conversion in a device.

Light energy \longrightarrow Electrical energy \longrightarrow Kinetic energy

Which one of the following devices shows the above energy conversion when in use?

- (1) A wound-up toy robot
- (2) A solar-powered toy car
- (3) A battery-powered toy car
- (4) A battery-powered torchlight

- 23 A plastic ball was dropped from position P above the ground. It bounced to a lower height each time it hit the ground as shown below until it finally stopped.

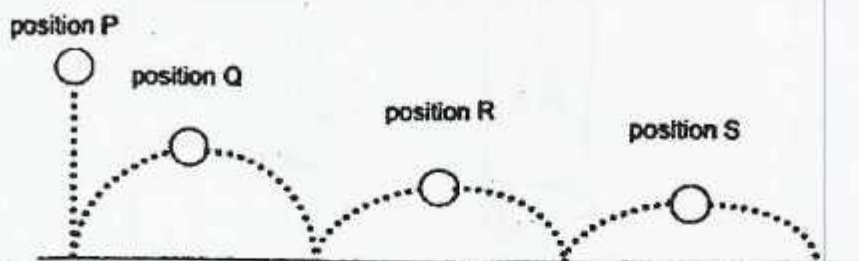

Which one of the following statements is/are correct?

- A: The potential energy of the ball increases from P to the ground.
 - B: The potential energy of the ball decreases from Q to the ground.
 - C: Some of its energy has been converted to heat and sound energy during its path.
- (1) A only
 - (2) C only
 - (3) B and C only
 - (4) A B and C

24 The picture below shows a cradle that will move the baby.

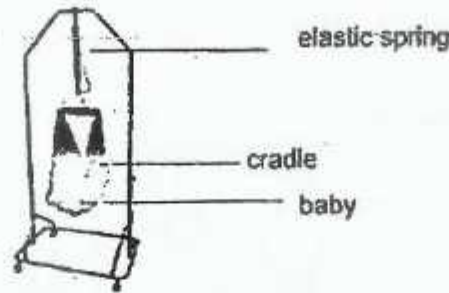

The elastic spring was pulled downwards and then released gently and the cradle moved up and down for a period of 30 seconds. Which of the following pairs of graphs correctly shows the potential energy possessed by the baby and the gravitational force that was acting on the baby for the 30 seconds?

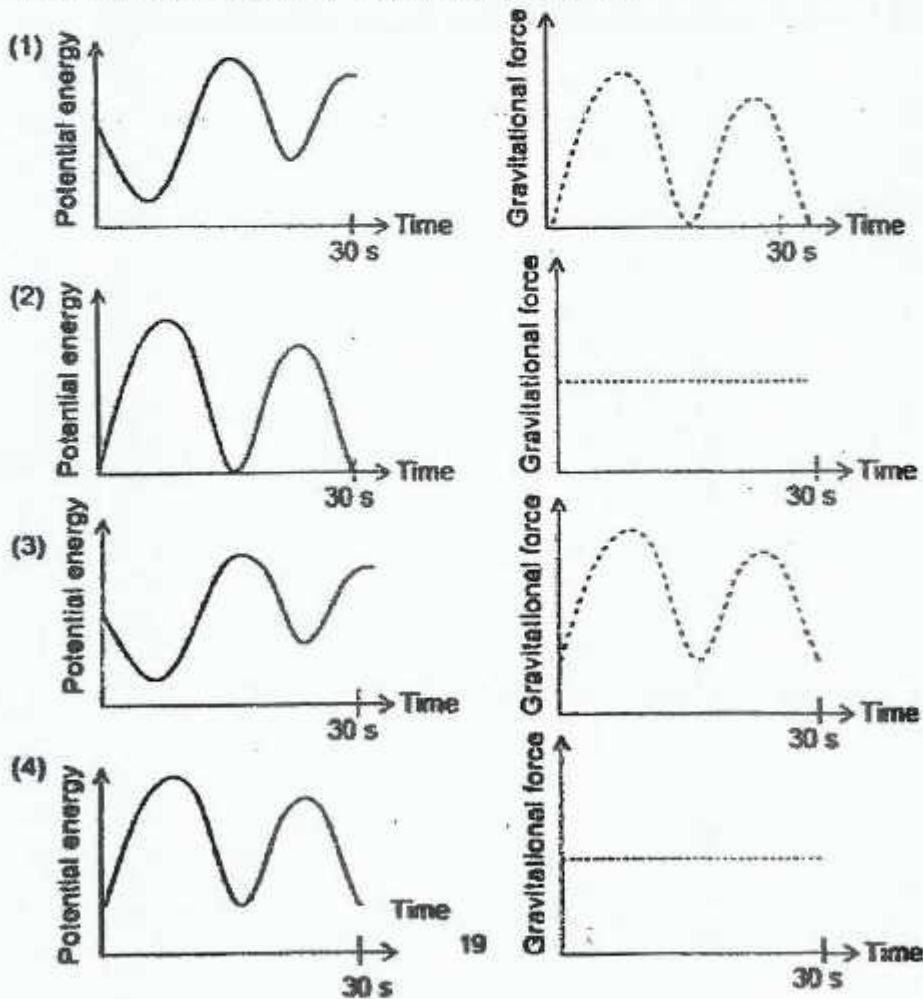

- 25 Samuel carried out an investigation to measure the distance travelled by a battery operated car on different tracks. The results were recorded in the table as shown below.

Track	Distance travelled (cm)
A	150
B	100
C	250
D	120

In which track was the greatest amount of heat energy and sound energy produced?

- (1) A
 (2) B
 (3) C
 (4) D
- 26 Nadia used a toy car, as shown below, to find out the relationship between the number of turns of the key and the distance it travelled.



Her results were recorded in the table below.

Number of turns of the key	2	4	6	8
Distance car travelled	10	20	30	40

Based on Nadia's results, which one of the following statements is true?

- (1) The faster the key was turned, the faster the toy car travelled.
 (2) The shorter the distance the toy car travelled, the more the potential energy it would have.
 (3) The greater the potential energy, the greater the kinetic energy the toy car would have.
 (4) The less the number of turns of the key, the greater the kinetic energy the toy car would have.

- 27 The diagram below shows the layers of cells in the cross-section of a leaf. John observed if there are chloroplasts in the cells A to D and recorded in the diagram as shown below.

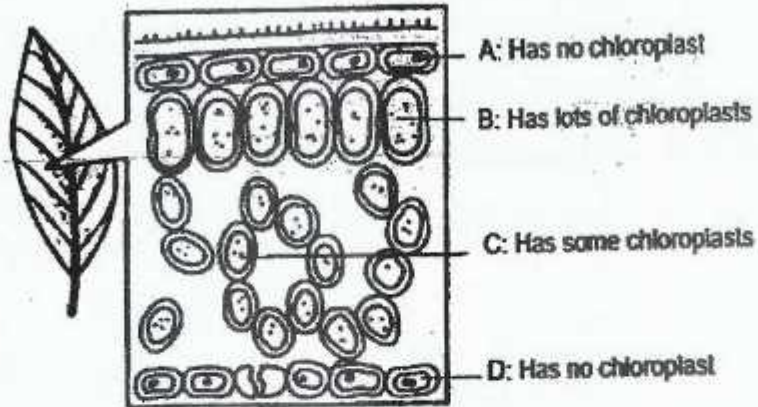

In which of the layers of cells A, B, C or D, will light energy be converted to potential energy?

- (1) A and B only
- (2) A and C only
- (3) B and C only
- (4) B, C and D only

- 28 Jason placed two different cubes on two identical springs. As a result, the springs in set-ups A and B were compressed as shown below.

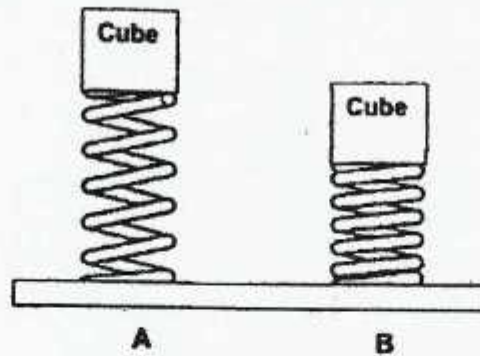

Based on his observation, Jason can infer that _____.

- (1) Cube in A is heavier than Cube in B
- (2) The spring in A has less potential energy than in B
- (3) The spring in A has more potential energy than in B
- (4) Cubes A and B have the same amount of potential energy

Go to booklet B

The first part of the document discusses the importance of maintaining accurate records of all transactions. It emphasizes that every entry should be supported by a valid receipt or invoice. This ensures transparency and allows for easy verification of the data.

In the second section, the author outlines the various methods used to collect and analyze the data. This includes both primary and secondary data collection techniques. The analysis focuses on identifying trends and patterns over time, which is crucial for making informed decisions.

The third part of the document provides a detailed breakdown of the results. It shows that there has been a significant increase in sales volume, particularly in the middle and lower income brackets. This is attributed to several factors, including targeted marketing campaigns and improved customer service.

Finally, the document concludes with a series of recommendations for future actions. It suggests that the company should continue to invest in research and development to stay ahead of the competition. Additionally, it recommends regular communication with customers to gather feedback and improve the overall user experience.

Appendix A: Data Tables



Rosyth School
Diagnostic Assessment 2021
STANDARD SCIENCE
Primary 6

Name: _____

Total
Marks:

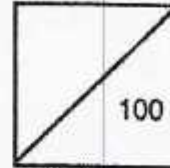

Class: Pr 6 _____ Register No. _____

Duration: Total time for Booklets A and B: 1 h 45 min

Date: 25 February 2021

Parent's Signature: _____

Booklet B

Instructions to Pupils:

1. For questions 29 to 40, write your answers in the spaces given in this booklet.

	Maximum	Marks Obtained
Booklet A	56 marks	
Booklet B	44 marks	
Total	100 marks	

* This booklet consists of 15 printed pages (including cover page).

This paper is not a weighted assessment. The purpose of this diagnostic assessment is to monitor your learning and to provide feedback.

This paper is not to be reproduced in part or whole without the permission of the Principal.



Faint title or header text centered at the top of the page.

Main body of faint text, possibly a list or a series of short paragraphs.

Faint table with multiple columns and rows, containing illegible data.

Additional faint text at the bottom of the page, possibly a conclusion or footer.

For questions 29 to 40, write your answers in the space provided. (44 Marks)

- 29 The flow chart below shows the processes involved in the human digestive system.

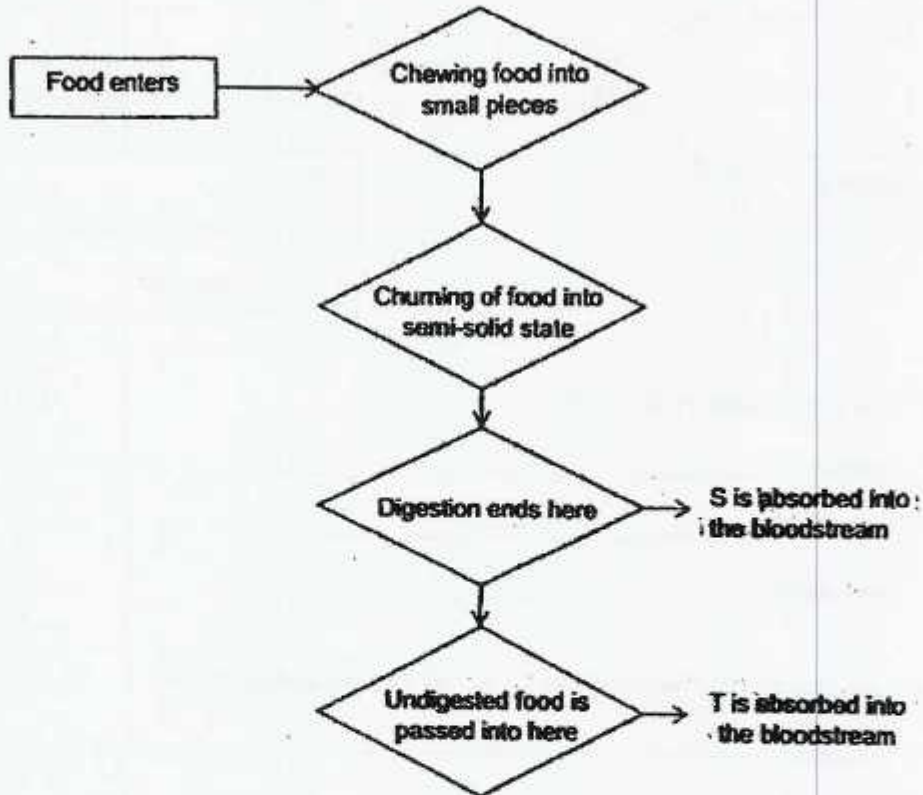

- (a) Based on the information given in the flow chart, identify S and T. [2]

S: _____ and T: _____

- (b) Small Intestine has many folds. How does having many folds help in its function? [1]

- 30 The diagram below shows how three body systems work together to provide the body with digested food and oxygen which are used by the body to produce energy.

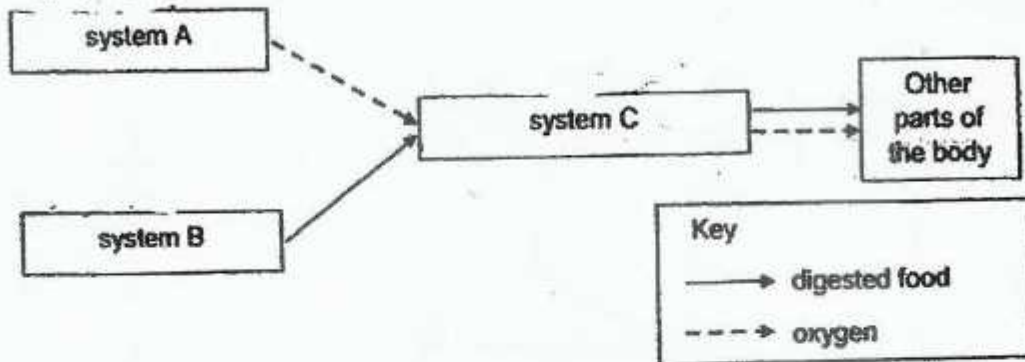

- (a) Identify systems A, B and C. [3]

system A: _____

system B: _____

system C: _____

- (b) Explain why our heart rate increases when we exercise faster. [2]

- 31 Xin Ming wanted to find out if sunlight is needed for photosynthesis. He put a well-watered plant in a dry and transparent glass tank. He then covered the tank with a black plastic bag for his experimental set-up, as shown below.

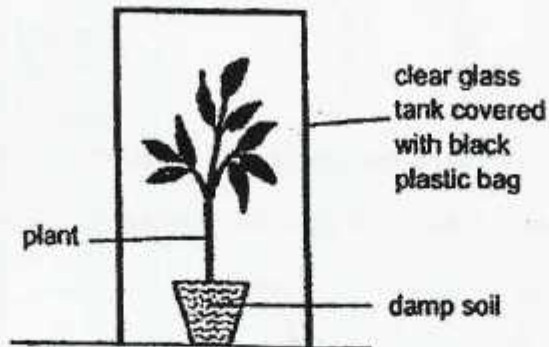

- (a) He needs a control set-up for his investigation. In the space below, draw and label the control set-up. [2]

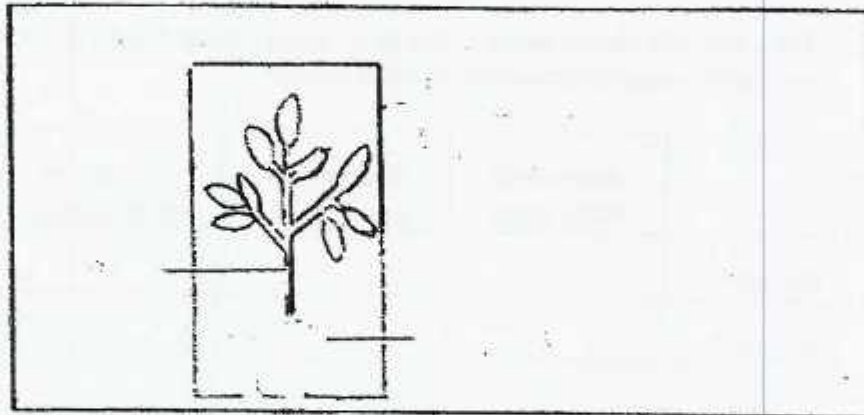

- (b) He placed the set-ups in the sun for several hours. In the table below, circle the correct answer to show how the percentages of carbon dioxide and oxygen would change inside the experimental set-up. [1]

Percentage of carbon dioxide	Increase / Remain the same / Decrease
Percentage of oxygen	Increase / Remain the same / Decrease

- 32 Arnold wanted to find out how the presence of water plants affects the survival of water snails. He was given the following items:



4 water snails



2 stalks of water plants

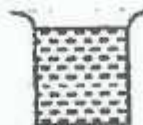

2 litres of water

Arnold prepared two set-ups, A and B. He used an air-tight jar for each set-up.



- (a) For a fair test, what quantity of the given items should Arnold put in the set-up A and set-up B? Complete the table below. [1]

	Amount of water (litre)	Number of water snails	Number of water plants
Set-up A			
Set-up B			

Arnold placed the two set-ups near a window. After some time, Arnold observed that the snails in one of the set-ups died while the snails in the other set-up remained alive.

- (b) What is the measured variable in this experiment? [1]
-
- (c) Why did the snails die in one of the set-ups? [2]
-
-

- 33 The diagram below shows an experiment to investigate how the colour of light will affect photosynthesis in pond weed.

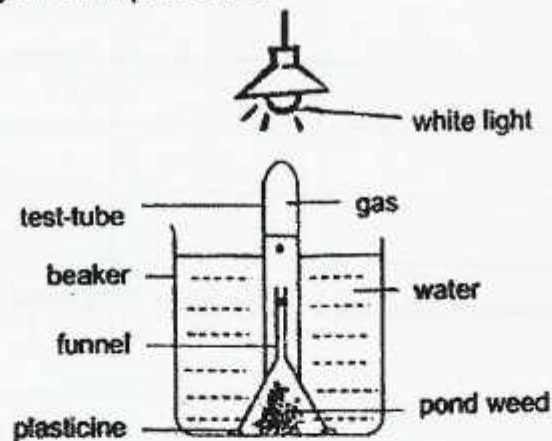

Bubbles of gas produced during photosynthesis were given off from the pond weed and collected in the test tube.

- (a) State two substances that are taken in by the pond weed for photosynthesis?

[2]

White, blue, green and red light were then shone, onto the same set-up one colour at a time. The number of bubbles of the gas given off in one minute was counted and recorded in the table below.

Colour of light	Number of bubbles given off in one minute
White	140
Blue	85
Green	10
Red	68

Question 33 is continued on page 7

(b)(i) Under which colour of light will pond weed grow the least? Explain. [2]

(c) What is the purpose of conducting the experiment using white light? [1]

- 34 John set up an experiment as shown in the diagram below. Three similar balls, A, B and C, were placed at different distances in front of a screen one at a time. A light is shone on them and the shadows of balls A, B and C were cast on the screen.

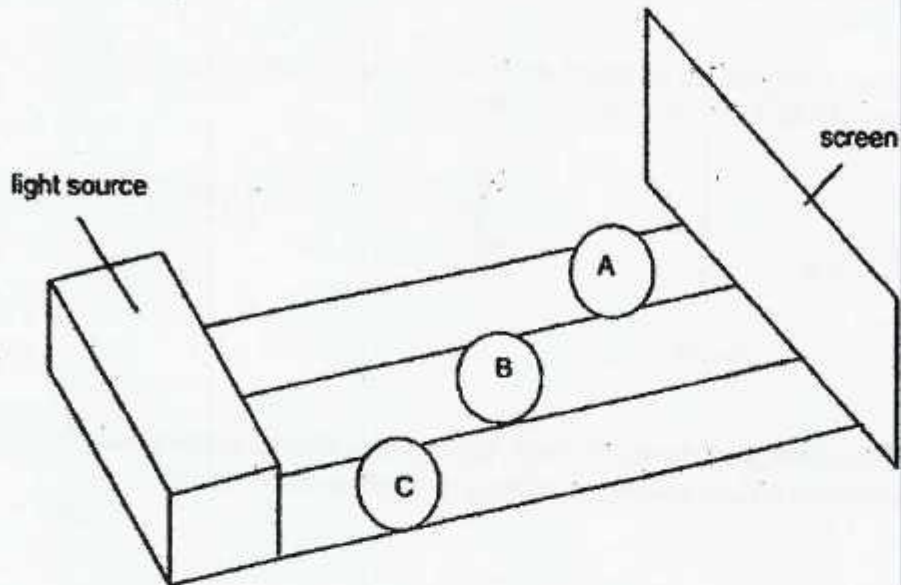

- (a) Write down A, B or C in the boxes provided below to correctly represent the shadows cast by the three different balls in the experiment above. [1]

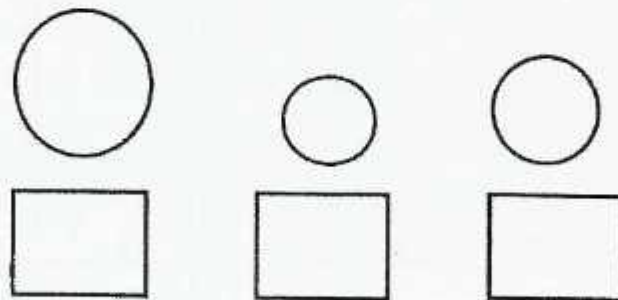

Question 34 is continued on page 9

- (b) If John were to move the screen further away from the balls, what will be the likely change to the size of the shadows of the three balls? [1]

In another set-up, John placed an object as shown below to form a shadow on the screen for the students to see from the other side.



- (d) The shadow formed on the screen has to be very dark. What properties must the materials of the screen and the object have, to produce such results? [2]

Screen : _____

Object : _____

- 35 Pei Hwa set up the experiment as shown below. Two similar cylindrical steel heaters, X and Y, of the same diameter and height but of different thickness, were both heated up to 130°C. Two similar beakers, each filled with 100ml of water, were placed on the cylindrical steel heaters.

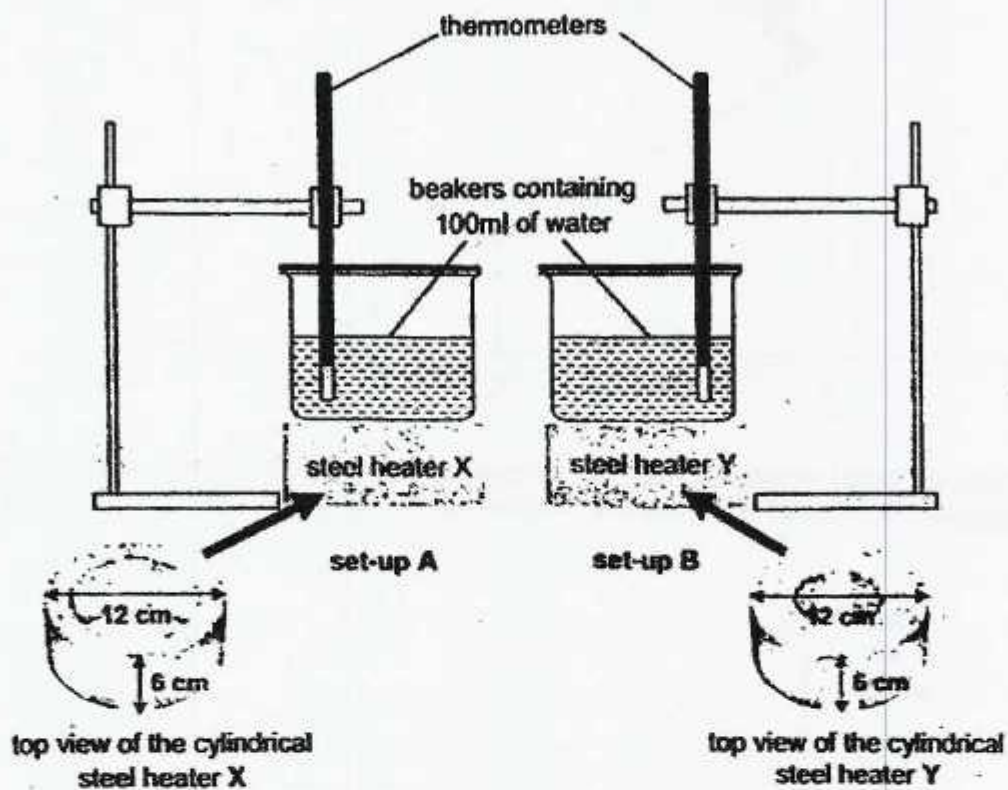

After 15 minutes Pei Hwa made the following observations:

- i. There was an increase in the temperature of water in both beakers.

(a) State the property of heat for the above observation in (i). [1]

- ii. A higher temperature of water was recorded in set-up B than in set-up A.

(b) Explain the above observation in (ii). [2]

36 The picture below shows a skier skiing down a slope starting from point A.

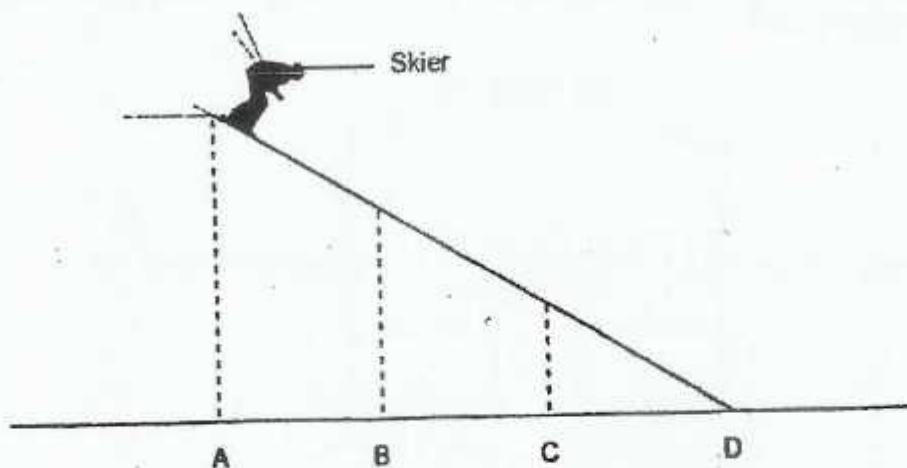

Draw and label two lines on the graph representing the amount of kinetic energy (—) and potential energy (- - -) the skier has from points A to D. [2]

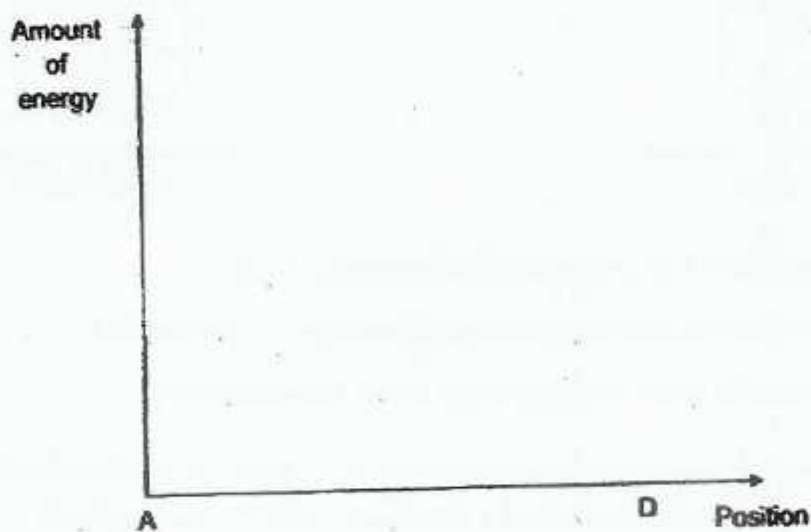

37 Ali conducted an experiment using the set-up as shown below.

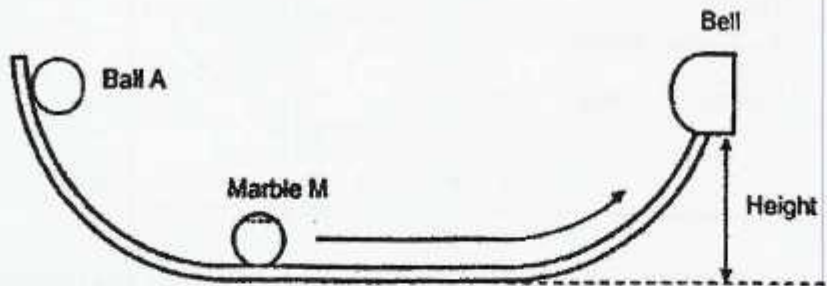

He wanted to find out the mass of the ball required to move marble M to hit the bell. Ball A was released to hit marble M. Marble M moved in the direction as shown in the set-up. He repeated the experiment with Balls B and C and recorded his results in the table below.

Ball	Mass of Ball (g)	Height moved by marble M	Did the bell ring?
A	150	50	Yes
B	120	45	No
C	90	40	No

(a) What is the relationship between the mass of the ball and the height moved by marble M? [1]

(b) The bell did not ring when Ball A was released from a lower position on the set-up. Explain this observation in terms of energy conversion. [2]

38 Andy released a yo-yo from a height .

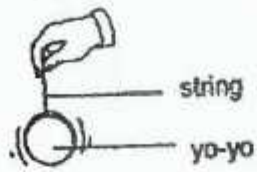

_____ floor

(a) Fill in the boxes to show the main energy conversion as the yo-yo was released from the hand to the floor. [1]



Andy observed that the yo-yo moved down and then up after it was released.

(b) Explain why the yo-yo first moved down and then up. [2]

(c) Explain why the yo-yo stopped completely after sometime. [1]

- 39 Huimin wanted to find out which heating coil, P or Q, produces more heat. She carried out the experiment at a room temperature of 27°C using the set-up shown below.

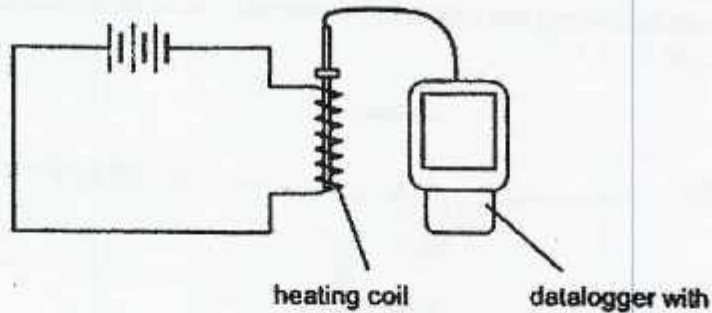

- (a) The temperature of the heating coil increased. Complete the energy change that caused this to happen. [1]

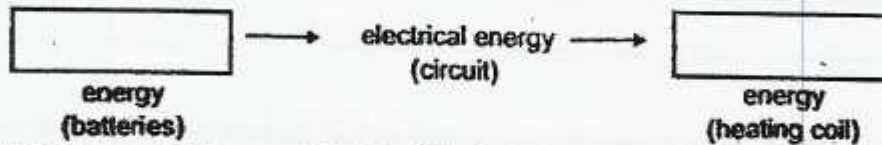

- (b) Huimin recorded her results in the table below.

Heating coil	Highest temperature reached (°C)
P	125
Q	83

She predicted that the batteries will last a shorter time when heating coil P was used. Explain how she came to this conclusion using her results. [2]

- (c) Huimin wants to find out if the number of batteries will affect the amount of heat produced by the heating coil. State two changes she should make to her set-up to meet this aim. [2]

- 40 Jacob wanted to find out if potential energy affects kinetic energy. He made a toy boat using some wood and a rubber band as shown below. The paddle of the boat was powered by twisting the rubber band around it. He set his toy boat in a bath tub and launched it.



- (a) What is the source of energy in the toy boat? [1]

- (b) Describe how he could carry out his experiment to show that potential energy affects kinetic energy. [2]

End of Paper

ANSWER KEY

YEAR : 2021
LEVEL : PRIMARY 6
SCHOOL : ROSYTH
SUBJECT : SCIENCE
TERM : DIAGNOSTIC ASSESSMENT (CA1)

BOOKLET A

Q1	3	Q2	3	Q3	3	Q4	4	Q5	2
Q6	4	Q7	3	Q8	3	Q9	3	Q10	3
Q11	1	Q12	3	Q13	4	Q14	2	Q15	2
Q16	4	Q17	1	Q18	1	Q19	3	Q20	2
Q21	4	Q22	2	Q23	3	Q24	4	Q25	2
Q26	3	Q27	3	Q28	2				

BOOKLET B

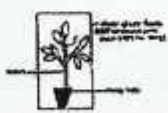
Q29	<p>a) S : Digested Food T : Water</p> <p>b) It increases the exposed surface area in contact with the blood vessels / bloodstream for faster absorption of digested food.</p>												
Q30	<p>a) System A : Respiratory System System B : Digestive System System C : Circulatory System</p> <p>b) The body needs more energy. The heart rate is faster to pump blood faster to transport more oxygen and digested food to the body parts to produce more energy.</p>												
Q31	<p>a)</p>  <p>b) Percentage of carbon dioxide : Increase Percentage of oxygen : Decrease</p>												
Q32	<p>a)</p> <table border="1" style="margin-left: 40px;"> <thead> <tr> <th></th> <th>Amount of water (litre)</th> <th>Number of water snails</th> <th>Number of water plants</th> </tr> </thead> <tbody> <tr> <td>Set-up A</td> <td>1</td> <td>2</td> <td>2</td> </tr> <tr> <td>Set-up B</td> <td>1</td> <td>2</td> <td>0</td> </tr> </tbody> </table> <p>b) The number of snails that survive.</p>		Amount of water (litre)	Number of water snails	Number of water plants	Set-up A	1	2	2	Set-up B	1	2	0
	Amount of water (litre)	Number of water snails	Number of water plants										
Set-up A	1	2	2										
Set-up B	1	2	0										

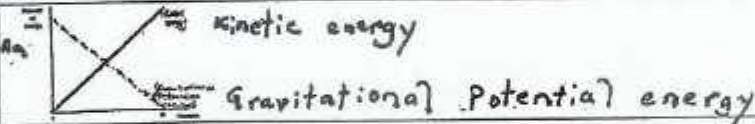
	c) The set-up with no water plants. There were no water plants to carry out photosynthesis and no oxygen was produced needed for the snails to survive.
Q33	<p>a) Water and carbon dioxide</p> <p>b) Green coloured light. During the experiment, the number of bubbles observed was the least which means the rate of photosynthesis is the least. Photosynthesis is the process of sunlight being taken in to make food in the presence of chlorophyll and carbon dioxide. So slower rate of photosynthesis mean least food is made. With least food, the plant will grow the least.</p> <p>c) To compare and confirm that the rate of photosynthesis is only affected by the colour of light and not any other variables.</p>
Q34	<p>a) C, A, B</p> <p>b) The size of the shadows of the 3 balls would increase.</p> <p>c) Screen : Translucent. Object : does not allow any light to pass through.</p>
Q35	<p>a) Heat travelled from a hotter region to a colder region.</p> <p>b) Beaker of water in set-up B has a greater contact with the steel heater, therefore heat transfer from the steel heat to the water is faster.</p>
Q36	 <p>Q36</p>
Q37	<p>a) As the mass of ball decreases. The height moved by marble M decreases.</p> <p>b) When marble A is put at a lower position. It has lesser gravitational potential energy. Thus, less gravitational potential energy would be converted to less kinetic energy and less kinetic energy would be transferred to marble M to hit the bell.</p>
Q38	<p>a) Gravitational potential energy \rightarrow kinetic energy</p> <p>b) As the yo-yo is released, its potential energy for it to move down when the yo-yo reached the bottom, the kinetic energy is converted back to potential energy for it to move up.</p> <p>c) After sometime. All kinetic energy would be converted to heat and sound energy.</p>
Q39	<p>a) Chemical potential \rightarrow electrical energy \rightarrow heat</p> <p>b) The temperature of the metal coil is higher when heating coil P was used more chemical potential energy in the battery is converted to more electrical energy in the circuit, then converted to more heat energy in heating coil P.</p> <p>c) Change heating coil P to another heat coil Q, prepare a few more batteries.</p>
Q40	<p>a) The twisted rubber band.</p> <p>b) Twist the rubber band 10 times measure the distance travelled by the toy boat. Twist the rubber band 20 times measure the distance travelled by the toy boat.</p>