

NANYANG PRIMARY SCHOOL

**PRELIMINARY EXAMINATION  
2023**

**PRIMARY 6**

**MATHEMATICS  
PAPER 1  
(BOOKLET A)**

Total Duration for Booklets A and B: 1 hour

Additional materials: Optical Answer Sheet (OAS)

**INSTRUCTIONS TO PUPILS**

1. Do not turn over this page until you are told to do so.
2. Follow all instructions carefully.
3. Answer all questions.
4. Shade your answers in the Optical Answer Sheet (OAS) provided.
5. The use of calculators is **NOT** allowed.

Name: \_\_\_\_\_ (      )

Class: Primary 6 (      )

Questions 1 to 10 carry 1 mark each. Questions 11 to 15 carry 2 marks each.  
For each question, four options are given. One of them is the correct answer.  
Make your choice (1, 2, 3 or 4) and shade your answer on the Optical Answer  
Sheet. (20 marks)

---

1 Round 76 523 to the nearest hundred.

(1) 76 500

(2) 76 000

(3) 77 000

(4) 80 000

2 In 89.76, which digit is in the tenths place?

(1) 6

(2) 7

(3) 8

(4) 9

- 3 What is the length of the paper clip in the figure below?

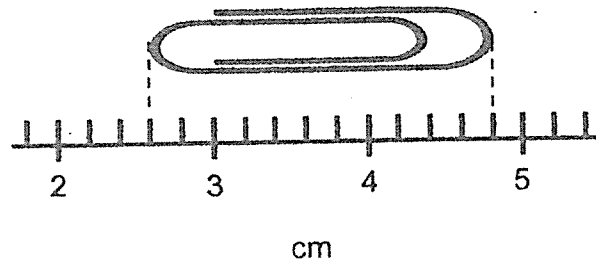

- (1) 1.1 cm  
(2) 2.2 cm  
(3) 2.6 cm  
(4) 4.8 cm
- 4 Which two lines in the square grid below are parallel to each other?

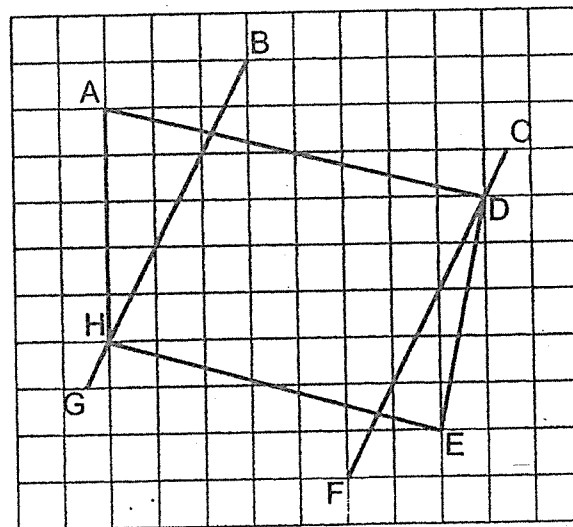

- (1) AD and HE  
(2) AH and DE  
(3) BG and DE  
(4) BG and CF

- 5 In the figure below, WPRT is a square. QWU and SWV are straight lines.  $\angle QWP = 13^\circ$  and  $\angle SWT = 28^\circ$ . Find  $\angle UWV$ .

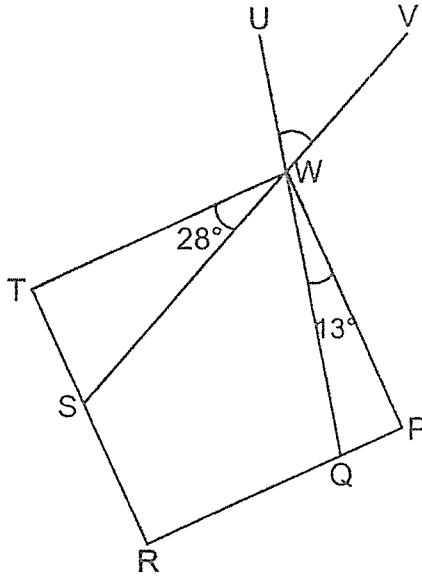

- (1)  $48^\circ$
- (2)  $49^\circ$
- (3)  $50^\circ$
- (4)  $51^\circ$

- 6 In the figure below,  $VWXY$  is a rhombus.  $XYZ$  is a straight line and  $\angle VWY = 36^\circ$ . Find  $\angle VYZ$ .

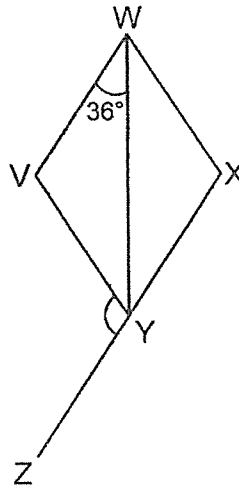

- (1)  $144^\circ$
- (2)  $112^\circ$
- (3)  $108^\circ$
- (4)  $72^\circ$

7 The figure below shows a cuboid.

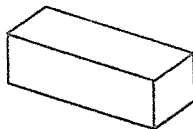

Which one of the following is **not** a net of the cuboid?

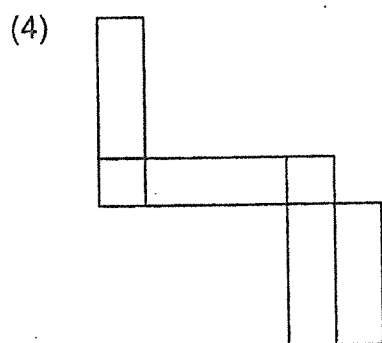
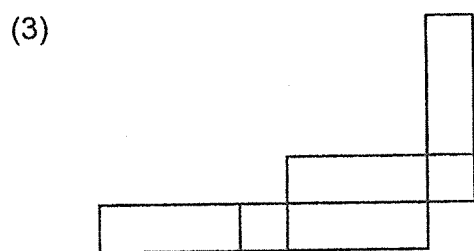
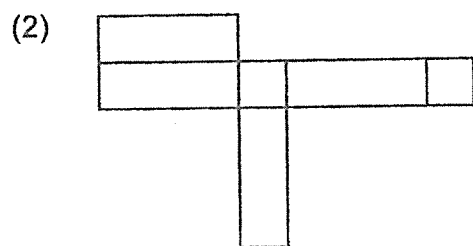
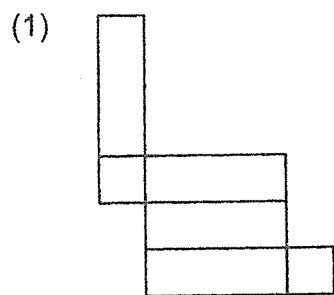

- 8 Kenneth had  $j$  pens at first. He gave away 9 pens and packed the remaining pens into 5 packets. There were 6 pens in each packet. How many pens did Kenneth have at first?

- (1) 20
- (2) 21
- (3) 30
- (4) 39

- 9 The pie chart shows the amount of money Jessica spent on the different items on her trip.

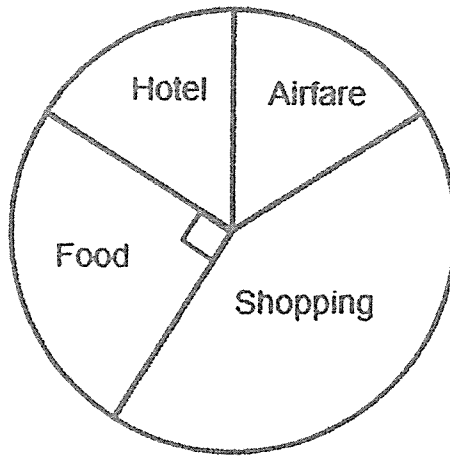

The amount of money Jessica spent on the different items on her trip is also represented by the bar graph below. The bar for the amount of money spent on shopping has not been drawn.

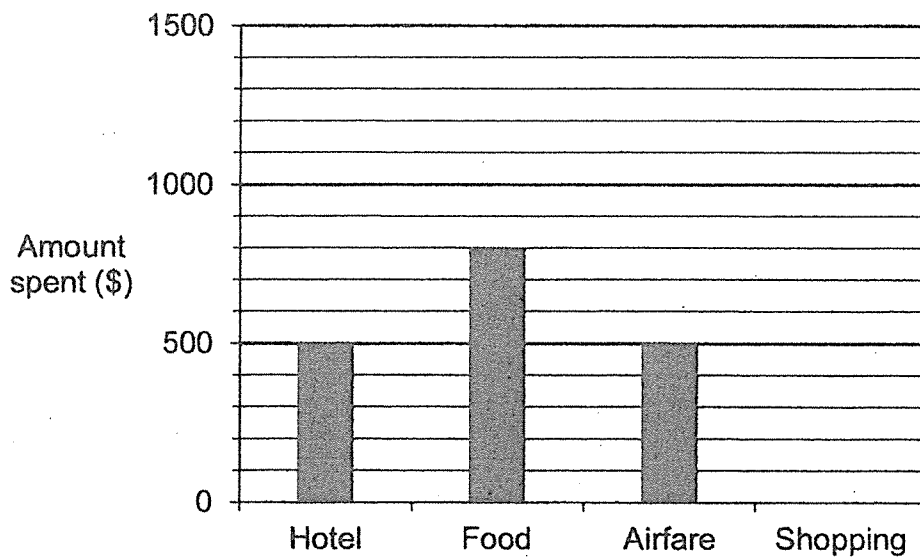

How much did Jessica spend on shopping?

- (1) \$1400
- (2) \$1600
- (3) \$1800
- (4) \$3200



- 10 The diagram shows the door of a classroom. Which of the following could be the height of the door?

- (1) 0.2 m
- (2) 2 m
- (3) 2 cm
- (4) 2000 cm

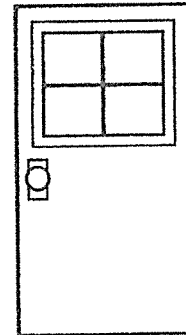

- 11 Three points are drawn on a square grid below.

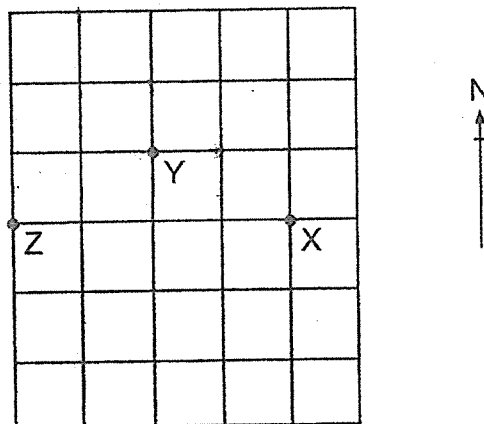

Eve is standing within the grid. She stands at a location north-west of X and north of Y. In what direction is Z from Eve?

- (1) South-east
- (2) South-west
- (3) North-east
- (4) North-west

- 12 Andy had 1600 white marbles and some black marbles at first. After buying 1200 red marbles,  $\frac{5}{9}$  of his marbles were black marbles and red marbles. What fraction of the marbles were red in the end?

(1)  $\frac{1}{3}$

(2)  $\frac{3}{4}$

(3)  $\frac{3}{7}$

(4)  $\frac{2}{9}$

- 13 Beaker A and Beaker B contain some water as shown below. How many more litres of water are there in Beaker A than Beaker B?

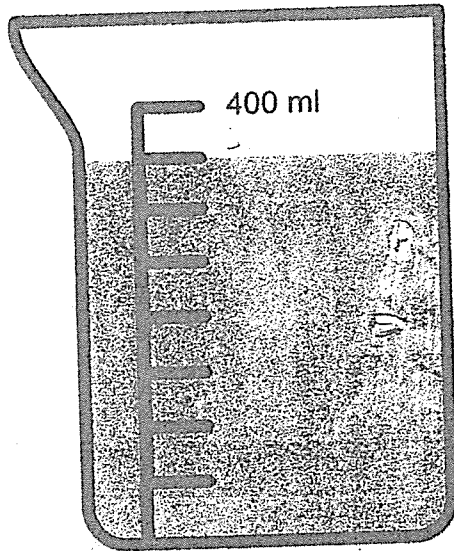

Beaker A

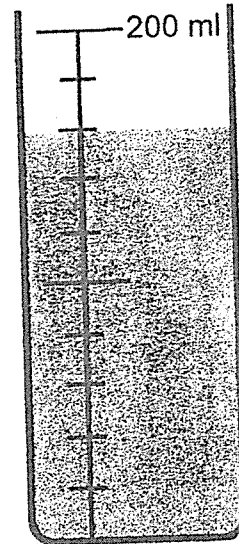

Beaker B

- (1) 210
- (2) 190
- (3) 0.21
- (4) 0.19

- 14 Mrs Raj baked some muffins.  $\frac{1}{4}$  of them were blueberry muffins,  $\frac{2}{5}$  of them were chocolate muffins and the rest <sup>were</sup> ~~are~~ strawberry muffins.

What was the ratio of the number of strawberry muffins to the number of blueberry muffins to the number of chocolate muffins?

- (1) 1 : 2 : 7
- (2) 2 : 5 : 3
- (3) 4 : 5 : 20
- (4) 7 : 5 : 8

- 15 Jun Xiang uses 4 letters K, L, M and N to form a pattern. The first 25 letters are shown below. What letter is in the 338<sup>th</sup> position?

K L M M K L N K L M M K L N K L M M K L N K L M M .....  
1<sup>st</sup> 25<sup>th</sup>

- (1) N
- (2) M
- (3) L
- (4) K

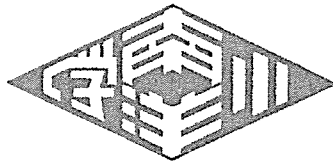

NANYANG PRIMARY SCHOOL

**PRELIMINARY EXAMINATION  
2023**

**PRIMARY 6**

**MATHEMATICS  
PAPER 1  
(BOOKLET B)**

Total Duration for Booklets A and B: 1 hour

**INSTRUCTIONS TO PUPILS**

1. Do not turn over this page until you are told to do so.
2. Follow all instructions carefully.
3. Answer all questions.
4. Write your answers in this booklet.
5. The use of calculators is **NOT** allowed.

Name: \_\_\_\_\_ (      )

Class: Primary 6 (      )

**Booklet B**

**/ 25**

Please sign and return the examination paper the next day. Any queries should be raised at the same time when returning paper.

Questions 16 to 20 carry 1 mark each. Write your answers in the spaces provided. For questions which require units, give your answers in the units stated. (5 marks)

---

- 16 Jane had 32 stickers. She gave  $\frac{3}{8}$  of her stickers to her cousin. How many stickers did she have left?

Ans: \_\_\_\_\_

---

- 17 Express 16 025 metres in kilometres.

Ans: \_\_\_\_\_ km

---

- 18 Shade the least number of squares to form a symmetric figure with line AB as the line of symmetry.

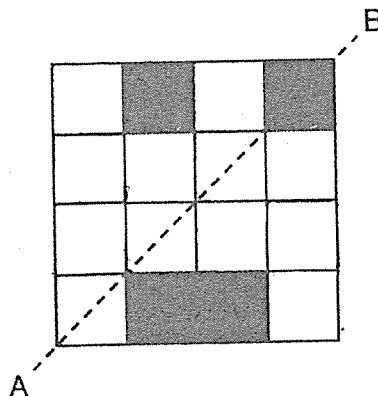

- 19 The solid below is made up of 1-cm cubes. Find the volume of the solid.

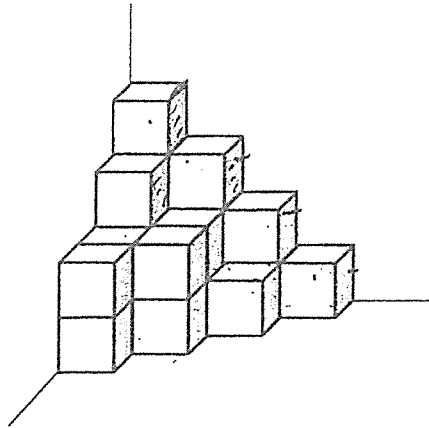

Ans: \_\_\_\_\_  $\text{cm}^3$

- 20 Govinder stacked 13 unit cubes and glued them together to form the solid below.

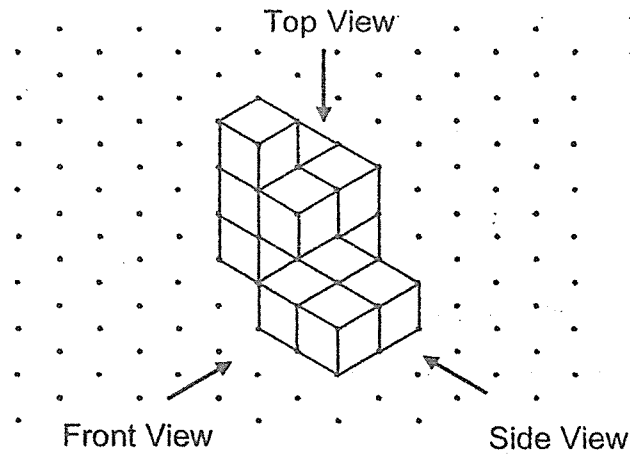

Draw the side view of the solid on the grid below.

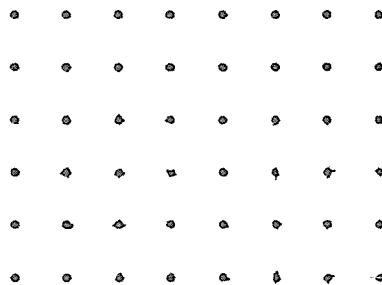

Questions 21 to 30 carry 2 marks each. Show your working clearly and write your answers in the spaces provided. For questions which require units, give your answers in the units stated. (20 marks)

---

21 List all the common factors of 12 and 42.

Ans: \_\_\_\_\_

---

22 Bala bought 3 pens and 2 files. The total cost of the 3 pens and 2 files was \$7.65.

(a) Bala gave the cashier \$50 to buy the 3 pens and 2 files. How much change did he receive?

Ans: \$ \_\_\_\_\_

(b) Chandra bought 9 such pens and 6 such files. How much did he pay?

Ans: \$ \_\_\_\_\_

---



- 23 Aminah arrived at a food centre at 17 05. She spent  $\frac{5}{12}$  h having dinner there. Then, she spent twice the amount of time travelling to a cinema. What time did she reach the cinema? Give your answer using the 24-hour clock.

Ans: \_\_\_\_\_

---

- 24 Mr Tan sold 40 cars in 2021. In 2022, he sold 50 cars. What was the percentage increase in the number of cars he sold from 2021 to 2022?

Ans: \_\_\_\_\_%

---

- 25 Xihuan used a calculator to divide a number by 7. She made a mistake by pressing 4 instead of 7. She obtained the incorrect answer of 287. What should the correct answer be?

Ans: \_\_\_\_\_

- 26 In the figure below, ABCD is a square. BGD and AGC are straight lines.  $BF = FC = CE$ . What fraction of the figure is shaded?

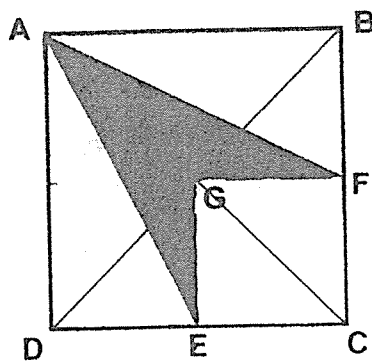

Ans: \_\_\_\_\_

- 27 Ali has 5 l of apple juice. He pours all the juice into cups. The capacity of each cup is  $\frac{7}{10}$  l. What is the least number of cups he uses for all his juice?

Ans: \_\_\_\_\_

---

- 28 In the figure below, EFG is an isosceles triangle. DEG is a straight line and  $EG = FG$ .  $\angle DEF = 111^\circ$  and  $\angle HGE = 63^\circ$ . Find  $\angle y$ .

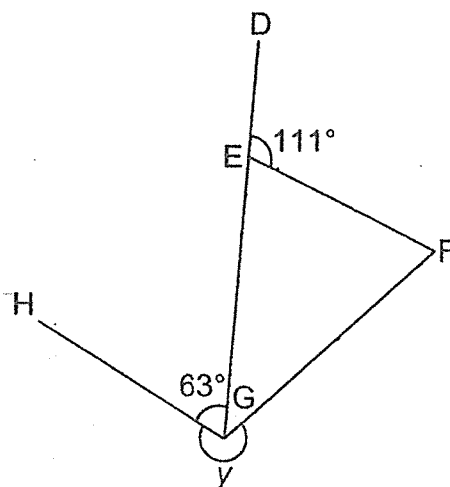

Ans: \_\_\_\_\_°

---

- 29 In the figure below, ACDE is a parallelogram and BDE is a triangle.  $\angle CAE = 75^\circ$ ,  $\angle BDC = 18^\circ$  and  $BE = BD$ . Find  $\angle AEB$ .

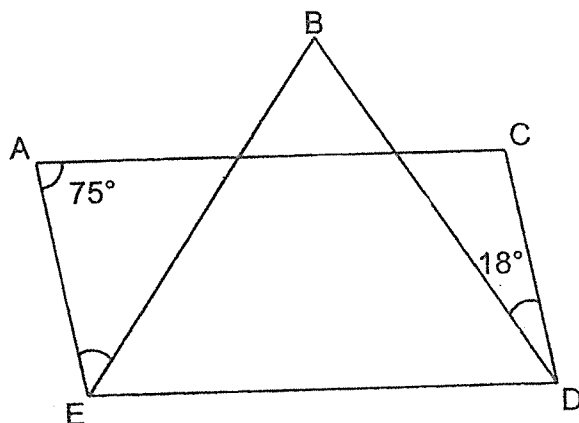

Ans: \_\_\_\_\_°

---

- 30 Mrs Tan had  $4y$  boxes of tarts. Each box contained 15 tarts. She sold 2 boxes of tarts. Given  $y = 8$ , how many tarts were left unsold?

Ans: \_\_\_\_\_

---

End of Paper

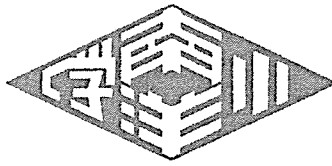

NANYANG PRIMARY SCHOOL

**PRELIMINARY EXAMINATION  
2023**

**PRIMARY 6**

**MATHEMATICS  
PAPER 2**

Duration: 1 hour 30 minutes

**INSTRUCTIONS TO PUPILS**

1. Do not turn over this page until you are told to do so.
2. Follow all instructions carefully.
3. Answer all questions.
4. Write your answers in this booklet.
5. The use of an approved calculator is allowed.

Name: \_\_\_\_\_ (       )

Class: Primary 6 (       )

Parent's Signature: \_\_\_\_\_

|                  |              |
|------------------|--------------|
| <b>Booklet A</b> | <b>/ 20</b>  |
| <b>Booklet B</b> | <b>/ 25</b>  |
| <b>Paper 2</b>   | <b>/ 55</b>  |
| <b>Total</b>     | <b>/ 100</b> |

Please sign and return the examination paper the next day. Any queries should be raised at the same time when returning paper.

Questions 1 to 5 carry 2 marks each. Show your working clearly and write your answers in the spaces provided. For questions which require units, give your answers in the units stated. (10 marks)

---

- 1 A lamp is 2 kg heavier than a vase. The total mass of 5 such lamps is  $k$  kg. Express the mass of the vase in terms of  $k$ .

Ans: \_\_\_\_\_ kg

---

- 2 The table shows how much a worker is paid each day.

|   |      |
|---|------|
| 1 <sup>st</sup> hour  | \$75 |
| Every additional hour   | \$40 |
| For every 4 hours of completed work, an additional \$10 will be paid. |      |

Mr Morris was paid \$325 for a day's work. How many hours did he work?

Ans: \_\_\_\_\_ h

---

- 3 X, Y and Z are 2-digit numbers. The average of X, Y and Z is 56. X is  $\frac{2}{3}$  of Y. Find the smallest possible value of X.

Ans: \_\_\_\_\_

---

- 4 What is the price of the handphone after adding 8% GST?

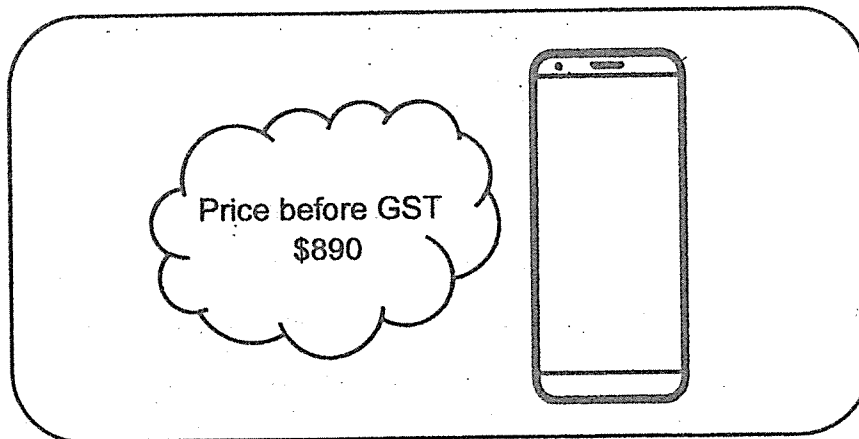

Ans: \$ \_\_\_\_\_

---

- 5 In the figure below, ABCD is a square and CEFG is a rectangle.  $\angle GCD = 203^\circ$ . Find  $\angle BCE$ .

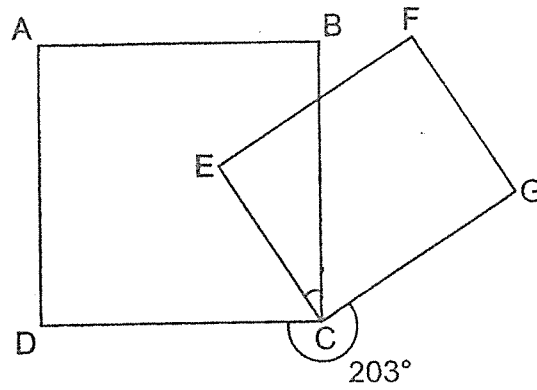

Ans: \_\_\_\_\_

---



For questions 6 to 17, show your working clearly and write your answers in the spaces provided. The number of marks available is shown in brackets [ ] at the end of each question or part-question. (45 marks)

- 6 A parallelogram ABCD is drawn on a square grid inside a box.

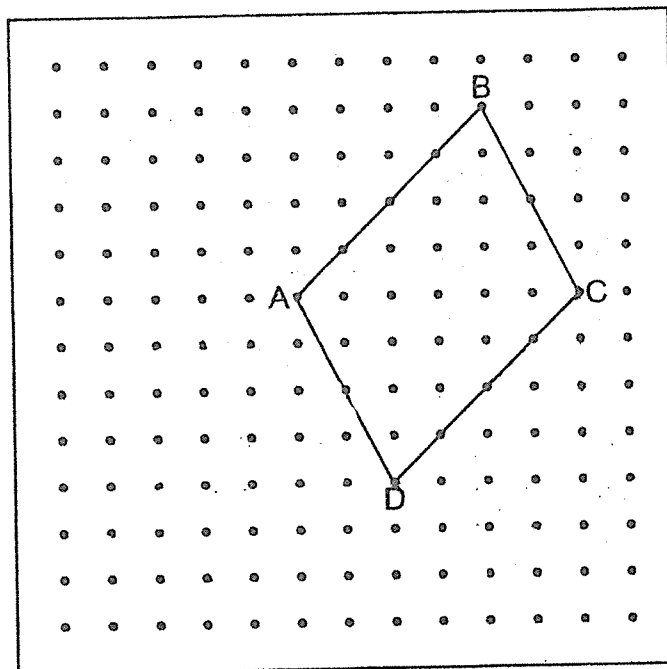

- (a) By joining dots on the grid with straight lines, draw square ADEF. Square ADEF must not overlap with parallelogram ABCD. [1]
- (b) By joining dots on the grid with straight lines, draw trapezium CDGH such that CD is twice as long as GH, GH is parallel to CD and  $DG = GH$ . Trapezium CDGH must not overlap with parallelogram ABCD. [1]
- (c) Find the ratio of the area of parallelogram ABCD to the area of square ADEF to the area of trapezium CDGH. Express your answer in its simplest form. [1]

Ans: (c) \_\_\_\_\_

- 7 At a bakery, Mrs Tan bought 9 chicken puffs and Mrs Lim bought 5 beef puffs. They spent the same amount of money buying these puffs. Each beef puff cost \$1.20 more than each chicken puff. How much money did Mrs Tan and Mrs Lim spend altogether?

Ans: \_\_\_\_\_ [3]

---

- 8 Janet, Samuel and Farhana used the same number of ice-cream sticks to make some popsicles. Janet had  $\frac{3}{7}$  of her ice-cream sticks left. Samuel had  $\frac{1}{4}$  of his ice-cream sticks left. Farhana had  $\frac{7}{9}$  of her ice-cream sticks left. They had a total of 1265 ice-cream sticks left. How many ice-cream sticks did each of them use to make popsicles?

Ans: \_\_\_\_\_ [3]

- 9 A group of 5 girls booked a computer for 2 hours. They took turns to work on the computer for their project. At any time, only 3 girls worked on the computer. On average, how long did each girl work on the computer? Give your answer in hours and minutes.

Ans: \_\_\_\_\_ [3]

---

- 10 At 08 00, Patrick and John travelled from Town A to Town B at constant speeds. They travelled along the same route. Patrick travelled at 25 km/h faster than John. When Patrick reached the mid-point between Town A and Town B, John was 30 km away from the mid-point. At what time did Patrick reach Town B?

Ans: \_\_\_\_\_ [3]

---

- 11 A 13-cm cubical container was filled with water to a height of 11 cm.

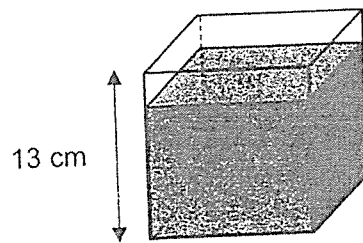

- (a) Find the volume of water in the cubical container.

Ans: (a) \_\_\_\_\_ [1]

- (b) Tank Y was filled with some water at first as shown below. All the water from the cubical container was poured into Tank Y. In the end, Tank Y was  $\frac{5}{7}$ -filled with water. Find the height of the water in Tank Y at first.

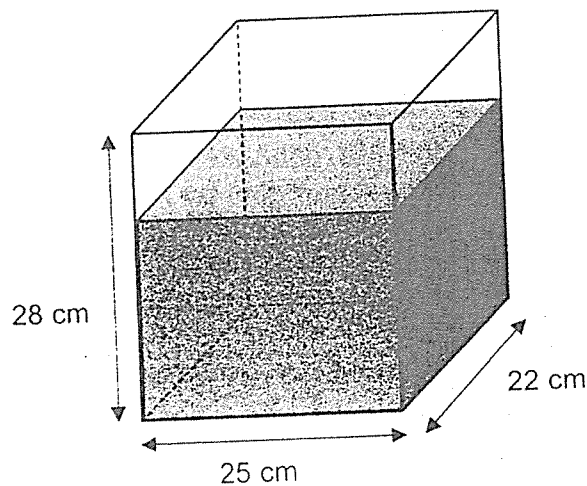

Ans: (b) \_\_\_\_\_ [3]

- 12 Shu Xin had a rectangular block measuring 32 cm by 12 cm by 24 cm. She painted all the faces of the block. Then, she cut the block into 2-cm cubes.

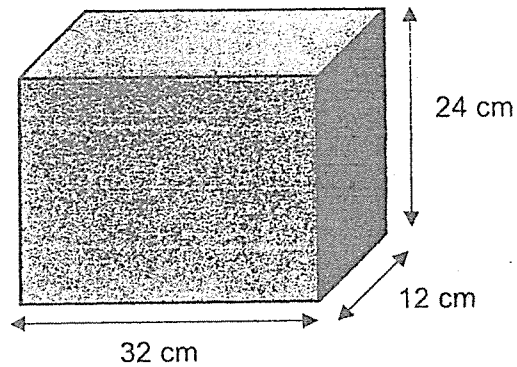

- (a) How many 2-cm cubes did Shu Xin cut from the block?

Ans: (a) \_\_\_\_\_ [2]

- (b) How many of these 2-cm cubes had none of the faces painted?

Ans: (b) \_\_\_\_\_ [2]

- 13 Some children sold cards for a fund-raising event. Each small card was sold at \$5 and each big card was sold at \$8. The table below shows the number of cards sold by three of the children.

| Child   | Number of cards sold |     |
|---------|----------------------|-----|
|         | Small                | Big |
| Janice  | 12                   | 7   |
| Deepa   | 7                    | 9   |
| Zi Ying | 6                    | 10  |

- (a) Which of the three children in the table above collected the most money? What was the amount of money collected?

Ans: (a) Child: \_\_\_\_\_

Amount: \_\_\_\_\_ [2]

- (b) Bradley sold as many cards as Deepa but collected \$15 less than her. How many small cards did Bradley sell?

(b) \_\_\_\_\_ [2]

14 In class 6T, when only one girl stands up and the rest of the children are sitting down, the number of boys sitting down is  $\frac{1}{2}$  the number of girls sitting down. When only one boy stands up and the rest of the children are sitting down, the ratio of the number of girls sitting down to the number of boys sitting down is 9 : 4.

(a) What is the total number of children in class 6T?

Ans: (a) \_\_\_\_\_ [2]

(b) After an equal number of girls and boys left the class for competition, the ratio of the number of girls to the number of boys in the class became 9 : 2. Find the total number of children who left the class for competition.

Ans: (b) \_\_\_\_\_ [2]



- 15 EFGH is a square.  $FG = MG$  and  $EK = JK$ . FGL, EMG, EKL and EHJ are straight lines.  $\angle FEL$  is twice of  $\angle FLE$ .

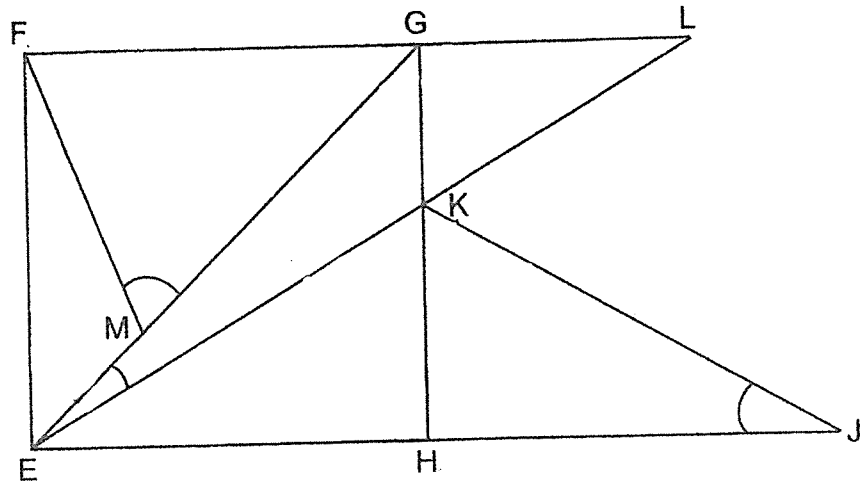

- (a) Find  $\angle FMG$ .

Ans: (a) \_\_\_\_\_ [1]

- (b) Find  $\angle GEL$ .

Ans: (b) \_\_\_\_\_ [2]

- (c) Find  $\angle KJE$ .

Ans: (c) \_\_\_\_\_ [1]

- 16 A company offered 150 laptops at a 20% discount during a 5-day sale. The line graph shows the number of laptops left unsold at the end of each day.

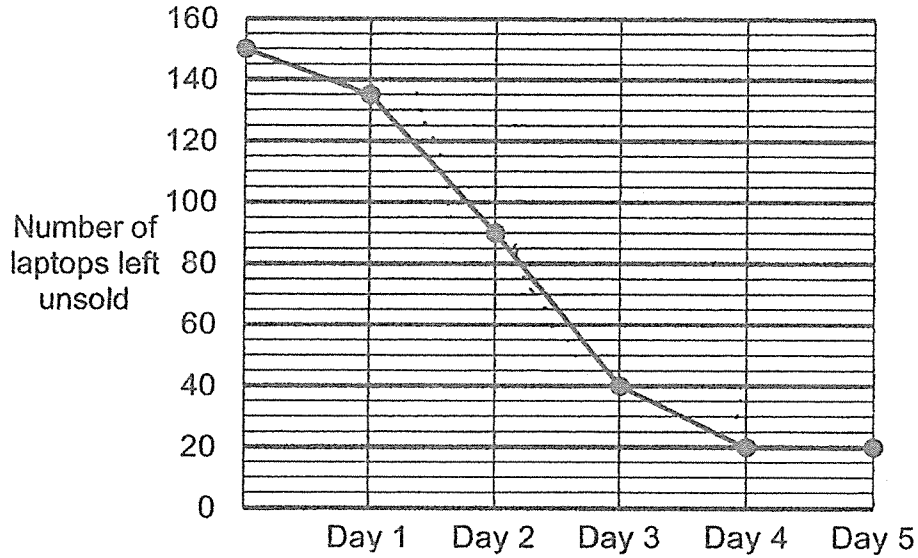

- (a) On which day was the most number of laptops sold?

Ans: (a) Day \_\_\_\_\_ [1]

- (b) What percentage of the laptops were sold on the first 2 days?

(b) \_\_\_\_\_ [1]

- (c) During the sale, the discounted price of the laptop was \$1288. After the sale, the remaining laptops were sold at a discount of 50% instead of 20%. What was the total amount of money collected from selling all 150 laptops?

(c) \_\_\_\_\_ [3]

- 17 The figure below is made up of a rectangle ABCD and a semicircle. AEC is a straight line. The arc of the semicircle touches AB at point F. DC = 16 cm and AF = FB.

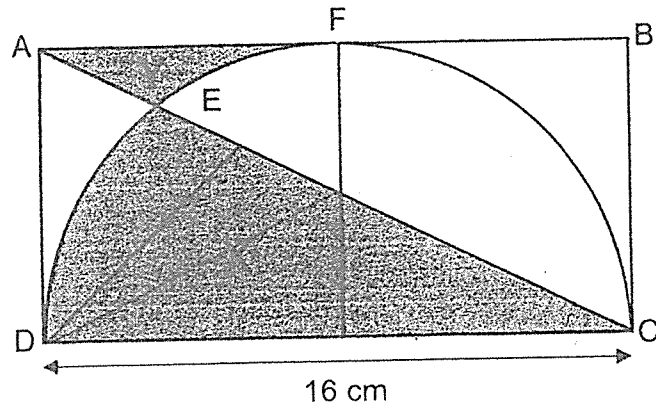

(Take  $\pi = 3.14$ )

- (a) Find the area of the semicircle.

Ans: (a) \_\_\_\_\_ [2]

- (b) Find the difference between Area X and Area Y.

Ans: (b) \_\_\_\_\_ [3]

---

End of Paper

EXAM PAPER 2023

LEVEL : PRIMARY 6  
 SCHOOL : NANYANG PRIMARY SCHOOL  
 SUBJECT : MATHEMATICS  
 TERM : PRELIMINARY EXAMINATIONS

BOOKLET (A)

|            |            |            |            |            |
|------------|------------|------------|------------|------------|
| <b>Q1</b>  | <b>Q2</b>  | <b>Q3</b>  | <b>Q4</b>  | <b>Q5</b>  |
| 1          | 2          | 2          | 4          | 2          |
| <b>Q6</b>  | <b>Q7</b>  | <b>Q8</b>  | <b>Q9</b>  | <b>Q10</b> |
| 3          | 3          | 4          | 1          | 2          |
| <b>Q11</b> | <b>Q12</b> | <b>Q13</b> | <b>Q14</b> | <b>Q15</b> |
| 2          | 1          | 4          | 4          | 3          |

**Booklet B**

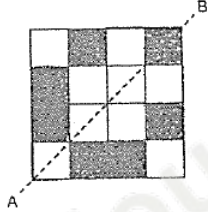
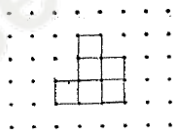
|    |   |
|----|---|
| 16 | 20  |
| 17 | 16.025km  |
| 18 |  |
| 19 | 22cm <sup>3</sup>   |
| 20 |  |
| 21 | 1,2,3 and 6   |
| 22 | a) \$42.35                      b) \$22.95  |
| 23 | 1820  |
| 24 | 25%   |
| 25 | 164   |
| 26 | $\frac{1}{4}$   |
| 27 | 8   |

|    |      |
|----|------|
| 28 | 255° |
| 29 | 48°  |
| 30 | 450  |

**Paper 2**

|   |   |
|---|---|
| 1 | <p>1 lamp <math>\rightarrow \frac{K}{5}</math></p> <p>1 vase <math>\rightarrow \left(\frac{K}{5} - 2\right)</math> (ans)</p>  |
| 2 | <p><math>\\$325 - \\$75 = \\$250</math></p> <p><math>\\$40 \times 3 + \\$10 = \\$130</math></p> <p><math>\\$250 - \\$130 = \\$120</math></p> <p><math>\\$120 \div \\$40 = 3</math></p> <p><math>4 + 3 = 7</math> (ans)</p>  |
| 3 | <p><math>x : y : \text{total}</math></p> <p><math>2 : 3 = 5</math></p> <p><math>56 \times 3 = 168 \rightarrow \text{total } x, y, z</math></p> <p>For <math>x</math> to be small, <math>z</math> has to be big</p> <p><math>168 - 99 = 69 \rightarrow \text{not multiple of } 5</math></p> <p><math>168 - 98 = 70</math></p> <p><math>70 \div 5 = 14</math></p> <p><math>14 \times 2 = 28</math> Ans: <u>28</u></p> |
| 4 | <p>100% <math>\rightarrow \\$890</math></p> <p>1% <math>\rightarrow \\$890 \div 100</math></p> <p><math>= \\$8.90</math></p> <p>108% <math>\rightarrow \\$8.90 \times 108</math></p> <p><math>= \\$961.20</math> (ans)</p>  |

|   |   |   |   |   |   |  |  |
|---|---|---|---|---|---|--|--|
| 5   | $\angle ECD = 360^\circ - 203^\circ - 90^\circ$ $= 67^\circ$ $\angle BCE = 90^\circ - 67^\circ$ $= 23^\circ \text{ (ans)}$  |   |   |   |   |  |  |
| 6   | <table style="width: 100%; border-collapse: collapse;"> <tr> <td style="width: 33%; vertical-align: top;">           ABCD,<br/> <math>\frac{1}{2} \times 6 \times 4 = 12</math><br/> <math>12 \times 2 = 24</math> </td> <td style="width: 33%; vertical-align: top;">           ADEF,<br/> <math>\frac{1}{2} \times 5 \times 2 = 5</math><br/> <math>5 \times 2 = 10</math><br/> <math>10 + 10 = 20</math> </td> <td style="width: 33%; vertical-align: top;">           CDGH,<br/> <math>\frac{1}{2} \times 4 \times 4 = 8</math><br/> <math>\frac{1}{2} \times 4 \times 2 = 4</math><br/> <math>8 + 4 = 12</math><br/>           Ans: (c)         </td> </tr> <tr> <td colspan="3" style="text-align: right; vertical-align: top;">           ABCD : ADEF : CDGH<br/> <math>24 : 20 : 12</math><br/> <math>6 : 5 : 3 \text{ (ans)}</math><br/> <u>6 : 5 : 3</u> </td> </tr> </table> | ABCD,<br>$\frac{1}{2} \times 6 \times 4 = 12$<br>$12 \times 2 = 24$   | ADEF,<br>$\frac{1}{2} \times 5 \times 2 = 5$<br>$5 \times 2 = 10$<br>$10 + 10 = 20$ | CDGH,<br>$\frac{1}{2} \times 4 \times 4 = 8$<br>$\frac{1}{2} \times 4 \times 2 = 4$<br>$8 + 4 = 12$<br>Ans: (c) | ABCD : ADEF : CDGH<br>$24 : 20 : 12$<br>$6 : 5 : 3 \text{ (ans)}$<br><u>6 : 5 : 3</u> |  |  |
| ABCD,<br>$\frac{1}{2} \times 6 \times 4 = 12$<br>$12 \times 2 = 24$                   | ADEF,<br>$\frac{1}{2} \times 5 \times 2 = 5$<br>$5 \times 2 = 10$<br>$10 + 10 = 20$   | CDGH,<br>$\frac{1}{2} \times 4 \times 4 = 8$<br>$\frac{1}{2} \times 4 \times 2 = 4$<br>$8 + 4 = 12$<br>Ans: (c) |   |   |   |  |  |
| ABCD : ADEF : CDGH<br>$24 : 20 : 12$<br>$6 : 5 : 3 \text{ (ans)}$<br><u>6 : 5 : 3</u> |   |   |   |   |   |  |  |
| 7   | $\$1.20 \times 5 = \$6$ $9 - 5 = 4$ $\$6 \div 4 = \$1.50 \rightarrow \text{each chicken}$ $\$1.50 \times 9 = \$13.50$ $\$13.50 \times 2 = \$27 \text{ (ans)}$   |   |   |   |   |  |  |

8

$$\text{Janet used} \rightarrow 1 - \frac{3}{7}$$

$$= \frac{4}{7}$$

$$= \frac{12}{21}$$

$$\text{Samuel used} \rightarrow 1 - \frac{1}{4}$$

$$= \frac{3}{4}$$

$$= \frac{12}{16}$$

$$\text{Farhana used} \rightarrow 1 - \frac{2}{9}$$

$$= \frac{2}{9}$$

$$= \frac{12}{54}$$

1st Common multiple of 4, 3 and 2  $\rightarrow$  12

$$\frac{3}{7} = \frac{9}{21}$$

$$\frac{1}{4} = \frac{4}{16}$$

$$\frac{2}{9} = \frac{42}{54}$$

$$9 + 4 + 42 = 55$$

$$55 \text{ units} = 1265$$

$$1 \text{ unit} = 1265 \div 55$$

$$= 23$$

$$\text{Ans: } \underline{\quad 276 \quad} [3]$$

$$12 \text{ units} = 23 \times 12$$

$$= 276 \text{ (ans)}$$

9

when 1 girl worked on the computer  $\rightarrow \frac{2}{5} \text{ h}$

$$\frac{2}{5} \text{ h} \times 3 = \frac{6}{5} \text{ h}$$

$$= 1\frac{1}{5} \text{ h}$$

$$= 1 \text{ h } 12 \text{ min (ans)}$$

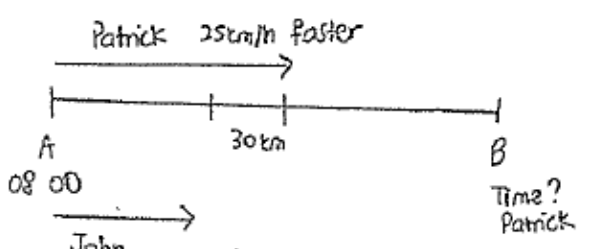
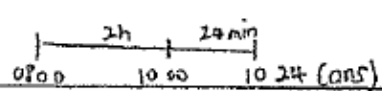
|    |  |
|----|--|
| 10 | <p>Patrick 25km/h faster</p>  <p>When Patrick reached B, John will be <math>30 \times 2 = 60</math> behind.</p> $60 \div 25 = 2.4$ $2.4 \text{ h} = 2 \text{ h } 24 \text{ min}$ <p>Ans: <u>10 24</u> [3]</p>  |
| 11 | $13 \times 13 \times 11 = 1859 \text{ cm}^3 \text{ (ans)}$ <p>Ans: (a) <u>1859 cm<sup>3</sup></u> [1]</p> $\frac{5}{7} \times 28 \times 25 \times 22 = 11000$ $11000 - 1859 = 9141$ $9141 \div 25 \div 22 = 16.62 \text{ cm (ans)}$ <p>Ans: (b) <u>16.62 cm</u> [3]</p>  |
| 12 | $32 \div 2 = 16$ $12 \div 2 = 6$ $24 \div 2 = 12$ $16 \times 6 \times 12 = 1152 \text{ (ans)}$ <p>Ans: (a) <u>1152</u> [2]</p>   |



$$16 - 2 = 14$$

$$6 - 2 = 4$$

$$12 - 2 = 10$$

$$14 \times 4 \times 10 = 560 \text{ (ans)}$$

Ans: (b) 560 [2]

13

$$\begin{aligned} \text{Janice} &\rightarrow (12 \times \$5) + (7 \times \$8) \\ &= \$116 \end{aligned}$$

$$\begin{aligned} \text{Deepa} &\rightarrow (7 \times \$5) + (9 \times \$8) \\ &= \$107 \end{aligned}$$

$$\begin{aligned} \text{Zi Ying} &\rightarrow (6 \times \$5) + (10 \times \$8) \\ &= \$110 \end{aligned}$$

Ans: (a) Child: Janice

Amount: \$116 [2]

$$7 + 9 = 16$$

$$\$8 - \$5 = \$3$$

$$\$15 \div \$3 = 5$$

$$7 + 5 = 12 \text{ (ans)}$$

$$\begin{aligned} \text{Check: } &12 \times \$5 + 4 \times \$8 \\ &= \$92 \end{aligned}$$

$$\$92 + \$15 = \$107$$

(b) 12 [2]

|    |   |
|----|---|
| 14 | <p>1 girl stand,      B : G : total<br/>1 : 2 : 3<br/><u>13 : 26 : 39</u></p> <p>1 boy stand,<br/>B : G : total<br/>4 : 9 : 13<br/><u>12 : 27 : 39</u></p> <p style="text-align: center;"><math>39 + 1 = 40 \text{ (ans)}</math></p> <p style="text-align: right;">Ans: (a) <u>40</u></p> <p>At first,                      End,</p> <p><del>G : B : Diff</del>                      <del>G : B : Diff</del></p> <p><u>27 : 13 : 14</u>                      <u>9 : 2 : 7</u></p> <p><u>18 : 4 : 14</u></p> <p><math>27 - 18 = 9</math><br/><math>9 \times 2 = 18 \text{ (ans)}</math></p> <p style="text-align: right;">Ans: (b) <u>18</u> [2]</p> |
| 15 | <p><math>\angle FGM = 45^\circ</math><br/><math>\angle FMG = \frac{180^\circ - 45^\circ}{2}</math></p> <p>a) <math>67.5^\circ</math></p> <p><math>\angle FEG = 45^\circ</math><br/><math>\angle GEL = 60^\circ - 45^\circ = 15^\circ \text{ (ans)}</math></p> <p>(b) <u>15°</u></p> <p><math>\angle KEJ = 90^\circ - 60^\circ = 30^\circ \text{ (ans)}</math><br/><math>= \angle KJE</math>      Ans: (c) <u>30°</u></p>  |
| 16 | <p>Ans: (a) Day <u>3</u> [1]</p>  |

$$150 - 90 = 60$$

$$\frac{60}{150} = \frac{2}{5} \quad (b) \quad \underline{40\%} \quad [1]$$
$$= 40\% \text{ (ans)}$$

$$100\% - 20\% = 80\%$$

$$80\% \rightarrow \$1288$$

$$1\% \rightarrow \$1288 \div 80$$

$$= \$16.10$$

$$50\% \rightarrow \$16.10 \times 50$$

$$= \$805$$

30

$$20 \times \$805 = \underline{\$183\ 540} \quad (c) \quad \underline{\$183\ 540} \quad [3]$$
$$= \$183\ 540 \text{ (ans)}$$

17

$$\text{radius} = 16 \div 2$$

$$= 8$$

$$\text{Area} = \frac{1}{4} \times 3.14 \times 8 \times 8$$

$$= 100.48 \text{ cm}^2 \text{ (ans)}$$

$$\text{Ans: (a)} \quad \underline{100.48 \text{ cm}^2} \quad [2]$$

$$X + Z - Z - Y = X - Y$$

$$\text{Area } \triangle ACD = \frac{1}{2} \times 8 \times 16$$

$$= 64$$

$$\text{Area of quarter circle} = \frac{1}{4} \times 3.14 \times 8 \times 8$$

$$= 50.24$$

$$\text{Area of boomerang AFD} \nabla = (8 \times 8) - (50.24) = 13.76$$

$$\text{Ans: (b)} \quad \underline{50.24 \text{ cm}^2} \quad [3]$$

$$\underline{64 - 13.76 = 50.24 \text{ cm}^2 \text{ (ans)}}$$