



RED SWASTIKA SCHOOL

2023 PRELIMINARY ASSESSMENT

MATHEMATICS PAPER 1

Name : _____ ()

Class : Primary 6 / _____

Date : 18 August 2023

BOOKLET A

15 Questions

20 Marks

Duration of Paper 1 (Booklets A & B): 1 hour

Note:

1. Do not open this Booklet until you are told to do so.
2. Read carefully the instructions given at the beginning of each part of the Booklet.
3. Do not waste time. If a question is difficult for you, go on to the next one.
4. Check your answers thoroughly and make sure you attempt every question.
5. In this booklet, you should have the following:
 - (a) Page 1 to Page 5
 - (b) Questions 1 to 15
6. You are not allowed to use a calculator.

Questions 1 to 10 carry 1 mark each. Questions 11 to 15 carry 2 marks each. For each question, four options are given. One of them is the correct answer. Make your choice (1, 2, 3 or 4). Shade the correct oval (1, 2, 3 or 4) on the Optical Answer Sheet. (20 marks)

1 $70\,000 + 2\,000 + 300 + 8 =$ _____

- (1) 72 380
- (2) 72 308
- (3) 72 038
- (4) 70 238

2 Round 769 481 to the nearest thousand.

- (1) 769 000
- (2) 769 480
- (3) 769 500
- (4) 770 000

3 Express $9\frac{1}{5}$ as a decimal.

- (1) 9.1
- (2) 9.2
- (3) 9.02
- (4) 9.15

4 The diagram shows a cup of milo sold in a school canteen.

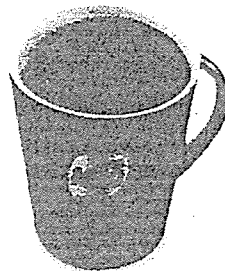

Which of the following could be the volume of the milo sold in the cup?

- (1) 20 ml
- (2) 20 l
- (3) 200 ml
- (4) 200 l

5. Mrs Tan bought 16 apples, 10 oranges and 2 watermelons. What was the ratio of the total number of apples and watermelons to the number of oranges?

- (1) 5 : 9
- (2) 5 : 14
- (3) 9 : 5
- (4) 14 : 5

6. The figure is made up of two triangles, PQR and STU.

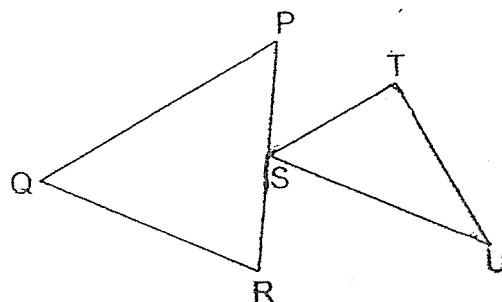

Which two lines in the figure are perpendicular to each other?

- (1) PQ and TS
- (2) PR and RQ
- (3) US and SR
- (4) UT and TS

7. What is the value of $\frac{2}{3} \div \frac{4}{5}$?

- (1) $\frac{8}{15}$
- (2) $\frac{5}{6}$
- (3) $1\frac{1}{5}$
- (4) $1\frac{7}{8}$

8 Which decimal is greater than 0.07 but smaller than 0.15?

- (1) 0.1
- (2) 0.9
- (3) 0.01
- (4) 0.19

9 Find the value of $\frac{80 - 2p}{2}$ when $p = 6$.

- (1) 27
- (2) 34
- (3) 54
- (4) 68

10 The table shows the number of points scored by different groups of students in a quiz.

Number of points scored	0	1	2	3	4
Number of groups	2	3	4	5	2

How many groups scored at least two points?

- (1) 5
- (2) 7
- (3) 9
- (4) 11

11 The table shows the height of different plants, W, X, Y and Z grown in a room over a month.

Plant	Height of plant at the start of the month	Height of plant at the end of the month
W	110 cm	127 cm
X	116 cm	131 cm
Y	119 cm	132 cm
Z	118 cm	129 cm

Which plant has the greatest increase in height?

- (1) W
- (2) X
- (3) Y
- (4) Z

- 12 Kamie is standing at K facing north.

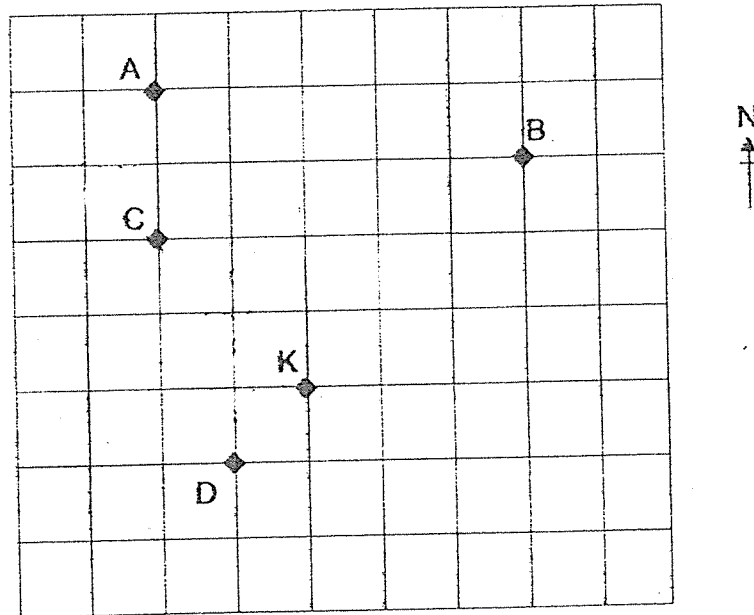

Kamie turns through an angle of 135° in an anti-clockwise direction, followed by $\frac{1}{4}$ - turn in the clockwise direction. Which point will Kamie be facing?

- (1) A
(2) B
(3) C
(4) D
- 13 The usual price of a study table was \$300. During a sale, Mrs Kumar bought 2 such study tables at a discount of 60%. How much was the total discount?
- (1) \$120
(2) \$180
(3) \$240
(4) \$360

- 14 Figure 1 is formed using four identical squares. The perimeter of Figure 1 is 80 cm. Another three identical squares were added to Figure 1 to form Figure 2.

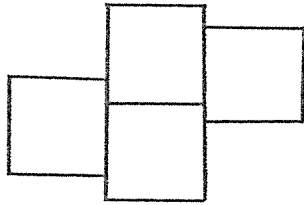

Figure 1

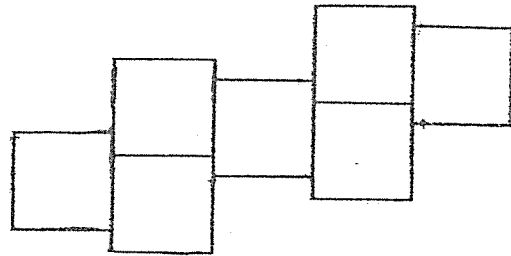

Figure 2

Find the perimeter of Figure 2.

- (1) 120 cm
 (2) 128 cm
 (3) 136 cm
 (4) 140 cm
- 15 Xavier planned to save \$21 using his pocket money. The table below shows his saving plan for his weekly pocket money from Monday to Friday.

Day	Amount saved
Monday	50 ¢
Tuesday	50 ¢
Wednesday	60 ¢
Thursday	60 ¢
Friday	80 ¢

Xavier started to save on a Friday. On which day of the week did Xavier managed to save exactly \$21?

- (1) Monday
 (2) Tuesday
 (3) Wednesday
 (4) Thursday



RED SWASTIKA SCHOOL

2023 PRELIMINARY ASSESSMENT

MATHEMATICS PAPER 1

Name : _____ ()

Class : Primary 6 / _____

Date : 18 August 2023

BOOKLET B

15 Questions
25 Marks

In this booklet, you should have the following:

- (a) Page 6 to Page 12
- (b) Questions 16 to 30

MARKS

	OBTAINED	POSSIBLE
BOOKLET A		20
BOOKLET B		25
TOTAL		45

Parent's Signature : _____

Questions 16 to 20 carry 1 mark each. Write your answers in the spaces provided. For questions which require units, give your answers in the units stated. (5 marks)

16 Write two hundred and five thousand and three in numerals.

Ans: _____

17 Find the value of $60 - 20 \div 2 + 4$.

Ans: _____

18 Find the value of $\frac{2}{3} \times 18$.

Ans: _____

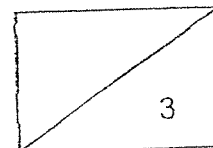

19 Find the value of $5 \div 8$. Express your answer as a decimal.

Ans: _____

20 Simplify $20r + 5r + 7 - r$.

Ans: _____

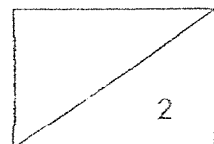

Questions 21 to 30 carry 2 marks each. Show your workings clearly in the space provided for each question and write your answers in the spaces provided. For questions which require units, give your answers in the units stated.

(20 marks)

21 Write an algebraic expression for the following.

(a) Subtract 15 from k .

Ans: (a) _____ [1]

(b) Jane typed 45 words in n minutes. Express the number of words she can type in 1 minute in terms of n .

Ans: (b) _____ [1]

22 Five letters, T, E, A, M and S are drawn on a square grid.

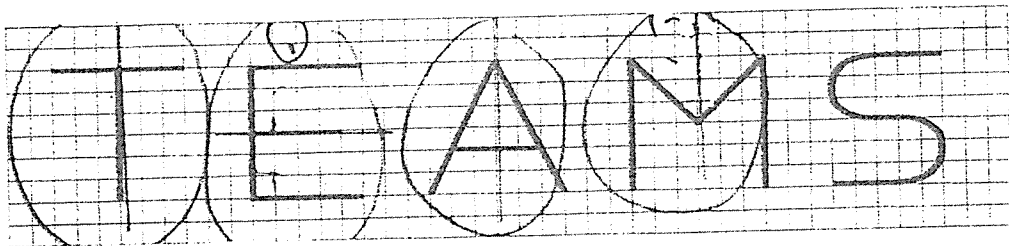

(a) How many of the letter(s) has / have a line of symmetry?

Ans: (a) _____ [1]

(b) Which letter(s) has/ have both parallel and perpendicular lines?

Ans: (b) _____ [1]

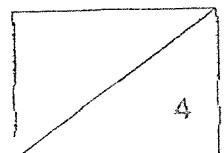

23 The net drawn for the solid shown below is incorrect.

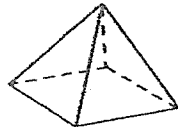

Solid

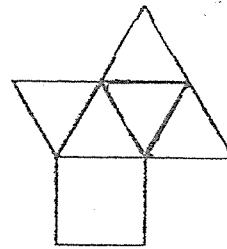

Net

(a) Name the solid.

Ans: (a) _____ [1]

(b) Shade a triangular face on the net that does not fit the net of the solid.

[1]

24 The table below shows the timing of the movie XYZ shown in a cinema.

Timing for movie XYZ
11.15 a.m.
2.30 p.m.
4.30 p.m.
7.15 p.m.
10.30 p.m.

(a) The duration of the movie is 2 h 10 mins. What time will the last screening of the movie XYZ end? Express your answer using the 24-hour clock.

Ans: (a) _____ [1]

(b) Wendy arrived at the cinema at 11.45 a.m. How long must she wait for the next screening of movie XYZ? Give your answer in h and min.

Ans: (b) _____ h _____ min [1]

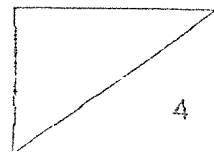

Use the information below to answer Questions 25 and 26.

The pie chart below shows the different ways a group of students go to school. The number of students who travel to school by car and MRT are represented in the bar graph.

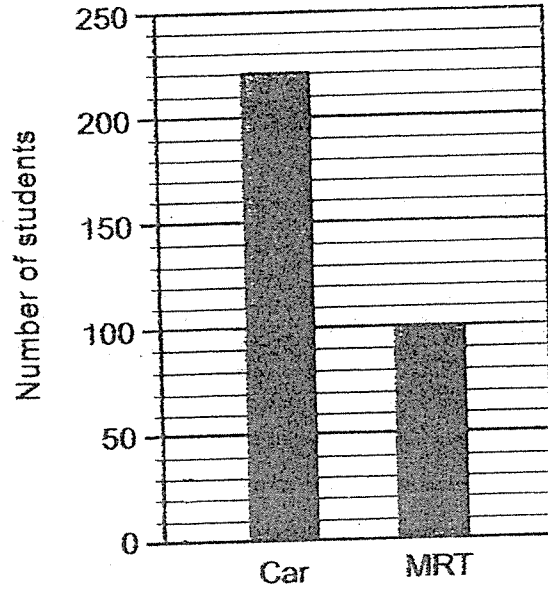
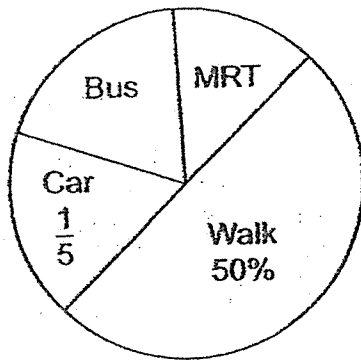

25 How many students walk to school?

Ans: _____

26 How many students travel to school by bus?

Ans: _____

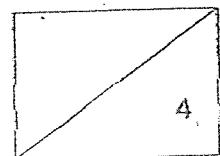

- 27 Machine A prints 10 pages more than Machine B every minute. Machine C prints half as fast as Machine A. The three machines print a total of 270 pages in 3 minutes. At this rate, how many pages does Machine C print in 1 minute?

Ans: _____

- 28 The figure ABCD is formed by two different squares and two identical rectangles. The area of the small square is $\frac{1}{4}$ the area of the big square.

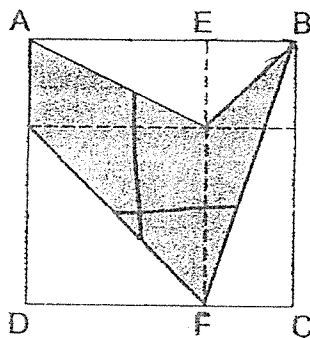

- (a) What fraction of EBCF is shaded?

Ans: (a) _____ [1]

- (b) What fraction of ABCD is shaded?

Ans: (b) _____ [1]

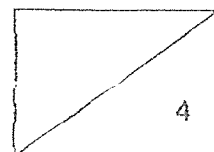

- 29 A group of students had an average of \$10. Three students with a sum of \$57 joined the group and the average amount of each student increased by \$3. How many students were there in the group at first?

Ans: _____

- 30 In the figure, ABC and DEF are right-angled triangles. The base of triangle DEF is twice as long as the base of triangle ABC. The height of triangle DEF is also twice as long as the height of triangle ABC. The difference in the area between the 2 unshaded parts is 18 cm^2 .

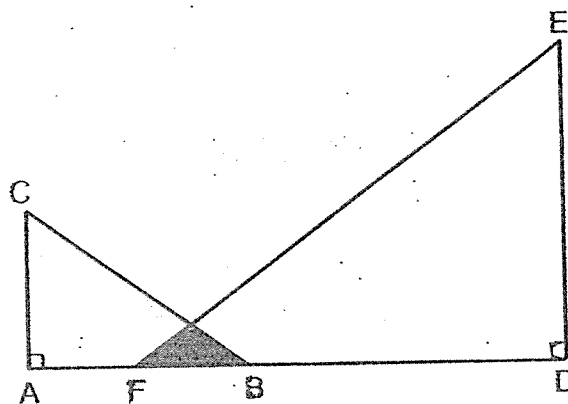

Each statement below is either true, false or not possible to tell from the information given above. For each statement, put a tick (\checkmark) to indicate your answer.

Statement	True	False	Not possible to tell
The ratio of the length AF to the length AB is 1 : 2.			
The area of triangle DEF is twice the area of triangle ABC.			
The area of triangle EFD is 24 cm^2 .			

END OF PAPER

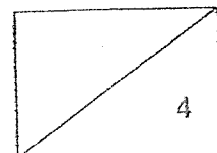



RED SWASTIKA SCHOOL

RED SWASTIKA SCHOOL

2023 PRELIMINARY ASSESSMENT

MATHEMATICS

PAPER 2

Name : _____ ()

Class : Primary 6 / _____

Date : 18 August 2023

17 Questions

55 Marks

Duration of Paper 2: 1 hour 30 minutes

Note:

1. Do not open this Booklet until you are told to do so.
2. Read carefully the instructions given at the beginning of each part of the Booklet.
3. Do not waste time. If a question is difficult for you, go on to the next one.
4. Check your answers thoroughly and make sure you attempt every question.
5. In this paper, you should have the following:
 - (a) Page 1 to Page 15
 - (b) Questions 1 to 17
6. You are allowed to use a calculator.

MARKS

	OBTAINED	POSSIBLE
PAPER 1		45
PAPER 2		55
TOTAL		100

Parent's Signature : _____

Questions 1 to 5 carry 2 marks each. Show your workings clearly in the space below each question and write your answers in the spaces provided. For questions which require units, give your answers in the units stated.

(10 marks)

-
- 1 (a) Write down all the common factors of 4 and 6.

Ans: (a) _____ [1]

- (b) What is the largest common multiple of 4 and 6 that is smaller than 50?

Ans: (b) _____ [1]

-
- 2 Mrs Devi had 2.5 m of ribbon at first. She used 8 cm of it.

- (a) Find the length of ribbon she had left in metres.

Ans: (a) _____ m [1]

- (b) Mrs Devi then cut the remaining length of the ribbon into two equal pieces. Find the length of each piece of the ribbon in centimetres.

Ans: (b) _____ cm [1]

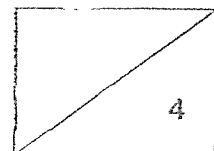

- 3 In the circle below, O is the centre and AOB is a straight line.

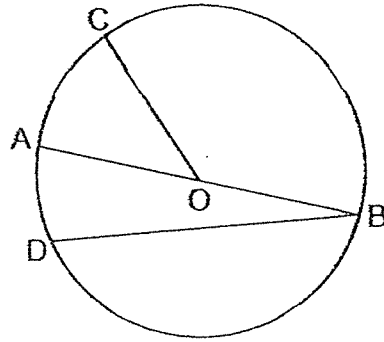

- (a) Measure and write down the diameter of the circle.

Ans: (a) _____ cm [1]

- (b) Using your answer in (a), find the circumference of the circle.
Leave your answer in terms of π .

Ans: (b) _____ cm [1]

-
- 4 The average of two different 3-digit numbers is 104. Write down one possible set of values for the two numbers.

Ans: _____ , _____

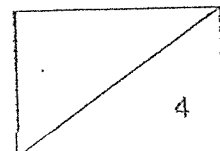

5. Vinesh has a rectangular piece of paper. He folded it along the dotted lines without overlapping as shown below.

Before folding

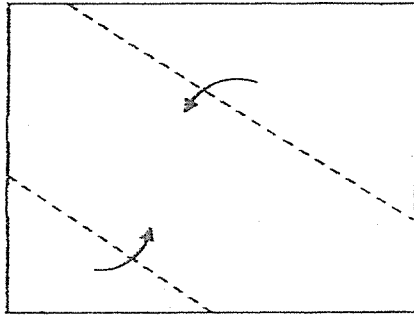

After folding

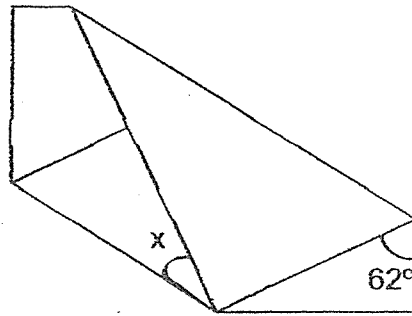

Find $\angle x$.

Ans: _____

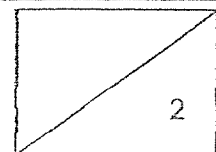

For Questions 6 to 17, show your workings clearly in the space below each question and write your answers in the spaces provided. The number of marks available is shown in brackets [] at the end of each question or part-question. (45 marks)

6 The total mass of three parcels was 13.8 kg. Parcel B was 1.2 kg heavier than Parcel A while Parcel C was 1.2 kg lighter than Parcel A.

(a) How much heavier was Parcel B than Parcel C?

Ans:(a) _____ [1]

(b) Find the mass of Parcel A.

Ans:(b) _____ [2]

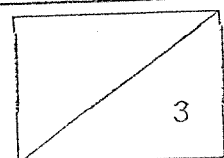

7 Ian drew a triangle ABX in a square grid as shown below.

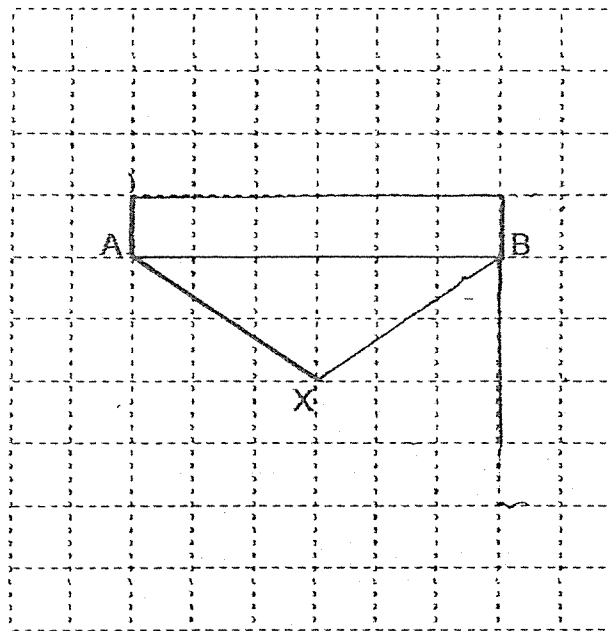

- (a) ABCD is a rectangle with the same area as triangle ABX. Draw ABCD on the grid above such that ABCD does not overlap with ABX. [1]
- (b) ABR is a right-angled triangle. The area of triangle BXR is the same as the area of triangle ABX. Draw ABR on the grid above such that ABR does not overlap with ABCD. [1]
- (c) Ian then drew another triangle Y in a square grid as shown below. Draw a parallelogram with the same perimeter as Y. Label the parallelogram P. [1]

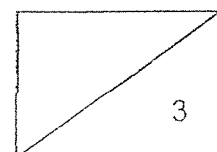
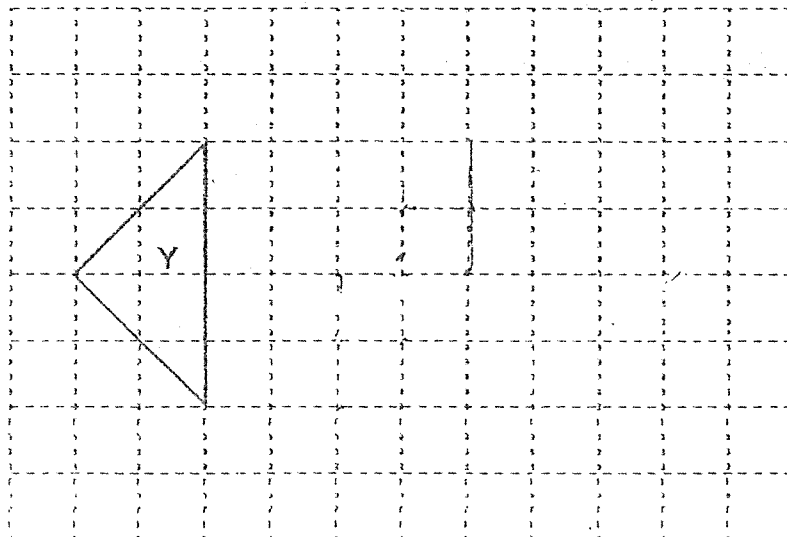

8 In the figure, ABCD is a rhombus and $AB = AE$.

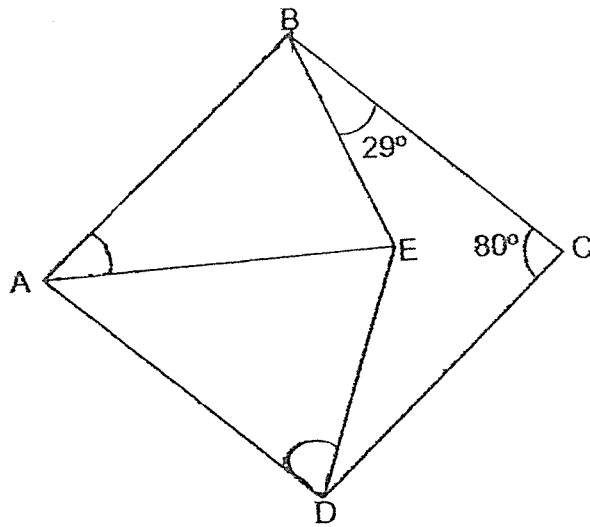

(a) Find $\angle BAE$.

Ans:(a) _____ [2]

(b) Find $\angle ADE$.

Ans:(b) _____ [2]

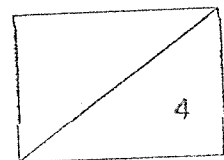

- 9 Jill glued 12 cubes of side 1 cm to form a solid as shown below.

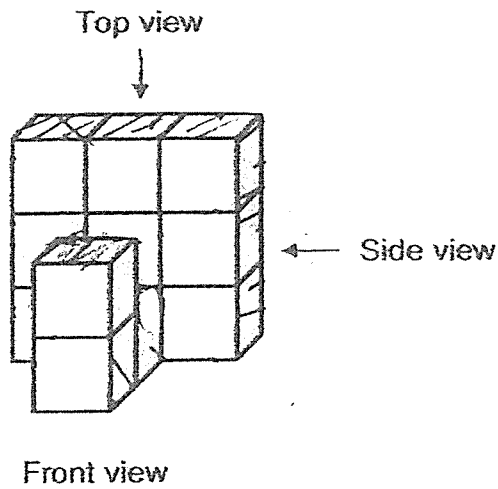

- (a) On the square grid below, draw the top view of the solid. [1]

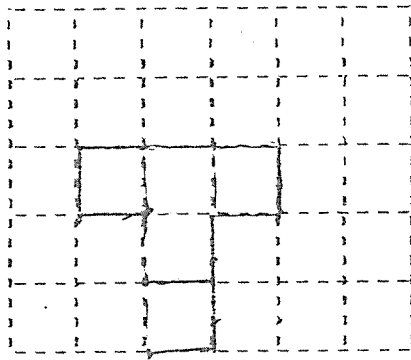

- (b) Jill painted the whole solid, including the base. How many cube(s) would have only two painted faces?

Ans:(b) _____ [1]

- (c) What was the total painted area of the solid?

Ans:(c) _____ [1]

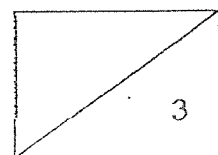

- 10 ABC is a triangle, BFC is a straight line and $\angle DEF$ is a right angle.

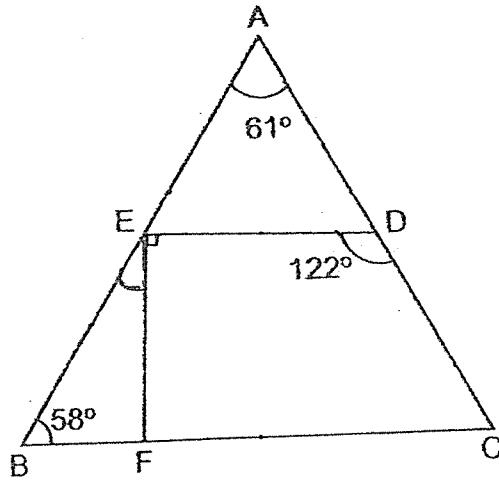

- (a) Find $\angle BEF$.

Ans:(a) _____ [2]

- (b) Circle the words that describe AED and CDEF correctly in the following statements:

AED (is / is not) an isosceles triangle and AD is equal to (AE / ED).
 CDEF (is / is not) is a trapezium and ED (is / is not) parallel to FC.

[2]

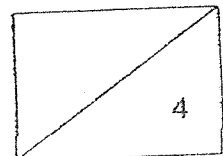

- 11 At first, 80% of a tank was filled with water. Chris turned on Tap A to allow water to flow out of the tank. 4 minutes later, Chris turned on Tap B to allow water to flow into the tank. After a while, both taps were then turned off at the same time.

The graph below shows the amount of water in the tank over 12 minutes.

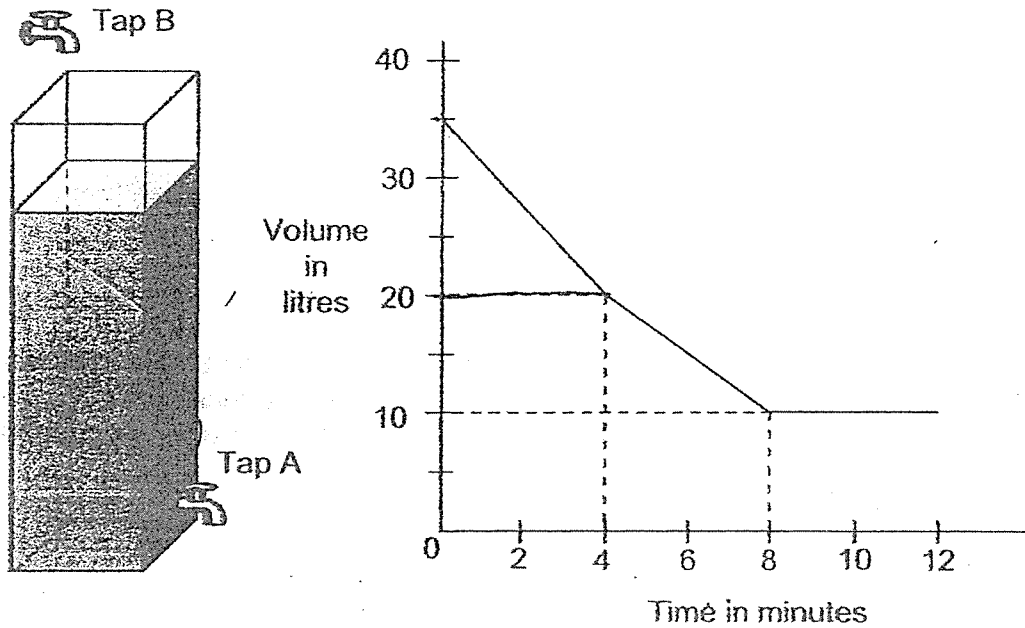

- (a) Find the capacity of the tank in litres.

Ans:(a) _____ [1]

- (b) How much water flowed out of the tank from tap A in 1 minute?

Ans:(b) _____ [1]

- (c) How much water flowed into the tank from tap B in 1 minute?

Ans:(c) _____ [2]

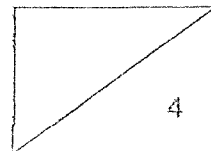

- 12 Sam had a bag of red, blue and green marbles. The ratio of the number of red marbles to the number of blue marbles was 2 : 1. The ratio of the number of blue marbles to the number of green marbles was 5 : 3.

(a) What fraction of Sam's marbles was green?

Ans:(a) _____ [1]

- (b) Sam removed 4 red marbles and 3 blue marbles from the bag each time. After a few rounds, there were 18 red marbles and 1 blue marble in the bag. How many red marbles were there in the bag at first?

Ans:(b) _____ [2]

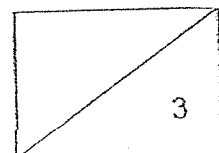

13 Janice sold 80 cakes in January. In February, she sold 30 more such cakes than in January.

- (a) What was the percentage increase in the number of the cakes sold from January to February?

Ans:(a) _____ [1]

- (b) The number of cakes she sold in March was a 100% increase from what she sold in February. How many cakes were sold in March?

Ans:(b) _____ [1]

- (c) The number of cakes sold in April was a 40% decrease from what she sold in January. The total number of cakes she sold in April and May was 200 when rounded off to the nearest hundred. What was the greatest possible number of cakes she sold in May?

Ans:(c) _____ [2]

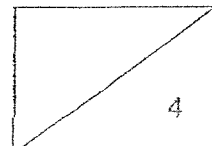

- 14 A market and a stadium are 240 m apart. They are located between Paul's and Rani's houses as shown below. The market is exactly half-way in between the two houses.

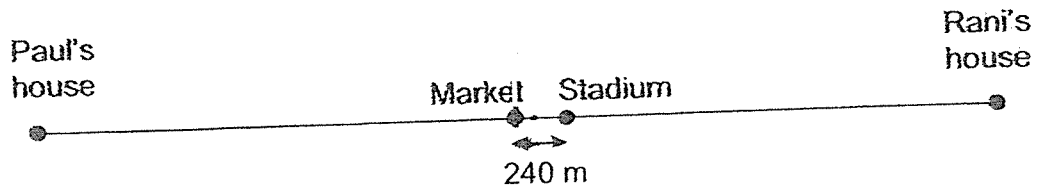

One morning, Paul and Rani started cycling from their houses at the same time and they arrived at the stadium together. Rani cycled at 100 m/min while Paul cycled at a speed 15 m/min faster than Rani.

- (a) How much further did Paul cycle than Rani?

Ans:(a) _____ [1]

- (b) How far was Rani's house from the stadium?

Ans:(b) _____ [3]

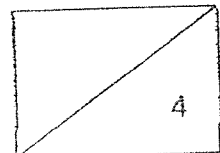

- 15 Shermaine used rectangular blocks to form figures that follow a pattern as shown below. The length of each block is 2 cm and its breadth is 1 cm.

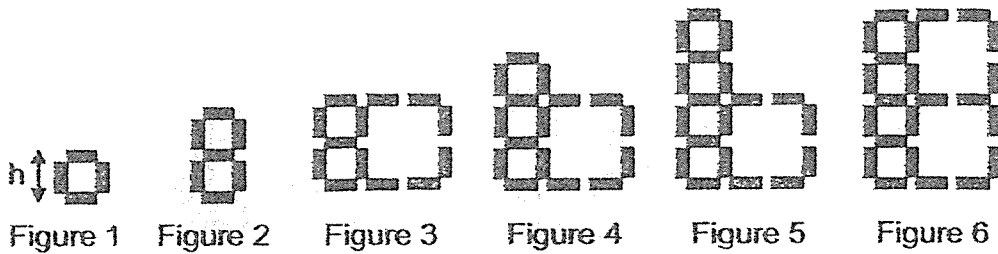

- (a) The table shows the number of rectangular blocks used for each figure. Complete the table for Figure 7.

Figure Number	Number of rectangular blocks used	Height of Figure (h)
1	4	4 cm
2	7	7 cm
3	13	7 cm
4	16	10 cm
5	19	13 cm
6	23	13 cm
7	_____	_____ cm

[1]

- (b) How many rectangular blocks were used in Figure 123?

Ans:(b) _____ [2]

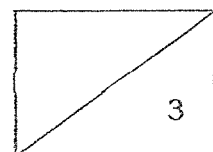

- 16 Leon designed a logo as shown. The logo is made up of two identical small semi-circles, a circle and a big quadrant. YZ is the diameter of the circle and O is the centre of the circle. X is the centre of the big quadrant and $XY = XZ$. The radius of the small semi-circle is 7 cm.

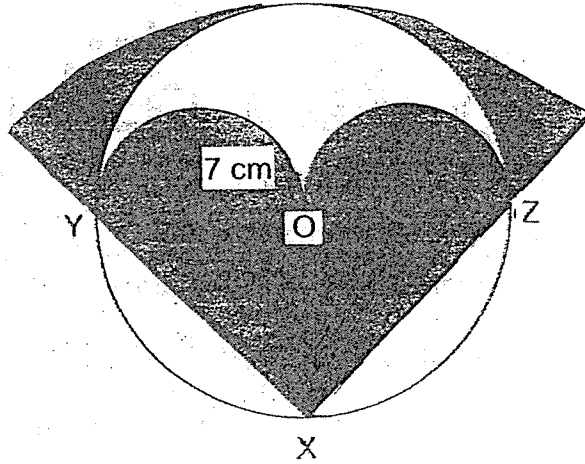

(Take $\pi = \frac{22}{7}$)

- (a) Find the length of YZ.

Ans:(a) _____ [1]

- (b) Find the area of triangle XYZ.

Ans:(b) _____ [1]

- (c) Find the total area of the shaded parts of Leon's logo.

Ans:(c) _____ [3]

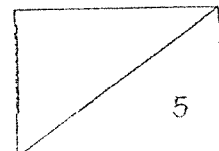

- 17 In a bakery, donuts and cupcakes are sold only in boxes. A box of 8 donuts costs \$15 and a box of 5 cupcakes costs \$7. Alice and Ben were given a sum of money to buy donuts and cupcakes from the bakery.

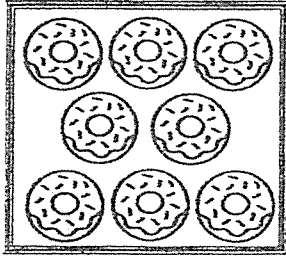

1 box of 8 donuts
\$ 15

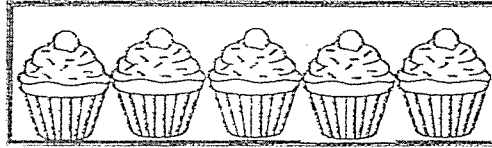

1 box of 5 cupcakes
\$ 7

Alice needed 20 donuts and 3 cupcakes for her party. After buying the donuts and cupcakes from the bakery, Alice passed the rest of the money to Ben.

- (a) What was the least amount of money Alice spend?

Ans:(a) _____ [1]

Ben spent $\frac{4}{7}$ of the rest of the money to buy donuts and cupcakes for his party and had $\frac{1}{3}$ of the sum of money left.

- (b) What fraction of the sum of money did Alice spend?

Ans:(b) _____ [1]

- (c) How many donuts and cupcakes did Ben buy?

Ans:(c) Donuts: _____ ,

Cupcakes: _____ [3]

END OF PAPER

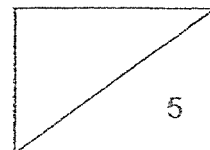

School : Red Swastika School
 Level : Primary 6
 Term : Preliminary Examination
 Subject : Mathematics
 Year : 2023

PAPER 1
BOOKLET A



Q1	Q2	Q3	Q4	Q5
2	1	2	3	3
Q6	Q7	Q8	Q9	Q10
4	2	1	2	4
Q11	Q12	Q13	Q14	Q15
1	3	4	2	4

16	205003
17	$= 60 - 10 + 4$ $= 50 + 4$ $= 54$
18	$\frac{2}{3} \times \frac{18}{1} = \frac{12}{1}$ $= 12$
19	$5 \div 8 = 0.625$
20	$(20r + 5r + 7 - r)$ $= (25r + 7 - r)$ $= (24r + 7)$
21	<p>a) $(k - 15)$</p> <p>b) $(\frac{45}{n})$</p>
22	<p>a) 4</p> <p>b) E and M</p>
23	<p>a) Pyramid</p>  <p>b)</p>
24	<p>a) 0040</p> <p>b) 2 h 45 min</p>

25	$220 \times 5 = 1100$ $1100 \div 2 = 550$																
26	$550 - 220 - 100 = 230$																
27	$270 - (10 \times 3) - (5 \times 3)$ $= 240 - 15$ $= 225$ $2 + 2 + 1 = 5$ $5 \times 3 = 15$ $15 + 5 = 20$																
28	<p>a) Area of $\Delta = \frac{1}{2} \times 2 \times 1 = 1u$</p> $\frac{2 \times 1}{2} = 1$ $3 \times 1 = 3$ Ans: $\frac{1}{3}$ <p>b) $\frac{2 \times 1}{2} = 1$</p> $\frac{2 \times 2}{2} = 2$ $3 \times 3 = 9$ $2 + 1 + 1 = 9$ Ans: $\frac{4}{9}$																
29	$10 \times 3 = 30$ $27 \div 3 = 9$ $9 - 3 = 6$																
30	<table border="1"> <thead> <tr> <th>Statement</th> <th>True</th> <th>False</th> <th>Not possible to tell</th> </tr> </thead> <tbody> <tr> <td>The ratio of the length AF to the length AB is 1 : 2.</td> <td></td> <td></td> <td>✓</td> </tr> <tr> <td>The area of triangle DEF is twice the area of triangle ABC.</td> <td></td> <td>✓</td> <td></td> </tr> <tr> <td>The area of triangle EFD is 24 cm².</td> <td>✓</td> <td></td> <td></td> </tr> </tbody> </table>	Statement	True	False	Not possible to tell	The ratio of the length AF to the length AB is 1 : 2.			✓	The area of triangle DEF is twice the area of triangle ABC.		✓		The area of triangle EFD is 24 cm ² .	✓		
Statement	True	False	Not possible to tell														
The ratio of the length AF to the length AB is 1 : 2.			✓														
The area of triangle DEF is twice the area of triangle ABC.		✓															
The area of triangle EFD is 24 cm ² .	✓																

Paper 2

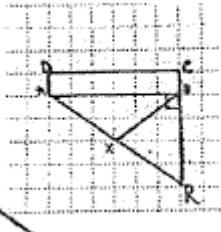
1	a) 1,2 b) 48
2	a) 2.42 b) $2.42m = 242cm$ $242cm \div 2 = 121cm$
3	a) 4.5 cm b) $\pi \times 4.5 = (4.5\pi)$
4	$(total) = 104 \times 2 = 208$ possible $\rightarrow 1^{st} = 100$ $2^{nd} = 208 - 100$ $= 108$ Ans: 100, 108

5	$2x = 180 - 28 - 90 = 62$ $x = \frac{62}{2}$ $= 31^\circ$
6	<p>a) $1.2 \text{ kg} + 1.2 \text{ kg} = 2.4 \text{ kg}$</p> <p>b) $3u = 13.8 \text{ kg} - (1.2 \text{ kg} \times 3) = 10.2 \text{ kg}$ $1u = 10.2 \text{ kg} \div 3 = 3.4 \text{ kg}$ $A = 1u + 1.2 \text{ kg}$ $= 3.4 \text{ kg} + 1.2 \text{ kg} = 4.6 \text{ kg}$</p>
7	
8	<p>a) $\angle ABC = 180^\circ - 80^\circ = 100^\circ$ $\angle ABE = 100^\circ - 29^\circ = 71^\circ$ $\angle BAE = 180^\circ - 71^\circ - 71^\circ = 38^\circ$</p> <p>b) $\angle EAD = 80^\circ - 38^\circ = 42^\circ$ $\angle ADE = \frac{180 - 42}{2} = 69^\circ$</p>
9	<p>a)</p>  <p>b) 2 c) $42 \times 1 = 42 \text{ cm}^2$</p>
10	<p>a) $\angle ACF = 180^\circ - 61^\circ - 58^\circ = 61^\circ$ $\angle ADE = 180^\circ - 122^\circ = 58^\circ$ $\angle AED = 180^\circ - 61^\circ - 58^\circ = 61^\circ$ $\angle BEF = 180^\circ - 61^\circ - 90^\circ = 29^\circ$</p> <p>b) $\triangle AED$ is an isosceles triangle and AD is equal to ED. $CDEF$ is not a trapezium and ED is not parallel to FC.</p>

11	<p>a) $\frac{35}{80} \times 100 = 43.75\%$</p> <p>b) $35 - 20 = 15$ $15 \div 4 = 3.75 \text{ } \ell$</p> <p>c) $3.75 \times 4 = 15$ $15 - 10 = 5$ $5 \div 4 = 1.25 \text{ } \ell$</p>						
12	<p>a) Total = $10u + 5u + 3u = 18u$ $= \frac{3}{18}$ $= \frac{1}{6}$</p> <p>b) Ans : 50</p>						
13	<p>a) $\frac{30}{80} \times 100 = 37.5\%$</p> <p>b) Feb = $80 + 30 = 110$ March = $\frac{110}{100} \times \frac{200}{1} = 220$</p> <p>c) $100 - 40 = 60$ April = $\frac{80}{100} \times \frac{60}{1} = 48$ (biggest) $201 + 48 = 249$ Ans : 201</p>						
14	<p>a) $240 + 240 = 480\text{m}$</p> <p>b) Time = $480 \div 15 = 32 \text{ min}$ Distance = $100 \times 32 = 3200\text{m} = 3.2\text{km}$</p>						
15	<p>a)</p> <table border="1" data-bbox="295 1227 834 1332"> <thead> <tr> <th>Figure No</th> <th>no of rec blk used</th> <th>(h)</th> </tr> </thead> <tbody> <tr> <td>7</td> <td>26</td> <td>16cm</td> </tr> </tbody> </table> <p>b)</p> <p>$123 \div 3 = 41$ 40 set of 10 $40 \times 10 = 400$ $400 + 13 = 413$</p>	Figure No	no of rec blk used	(h)	7	26	16cm
Figure No	no of rec blk used	(h)					
7	26	16cm					
16	<p>a) $D = 7 \times 2 = 14$ Big D = $14 \times 2 = 28\text{cm}$</p> <p>b) Big r = $28 \div 2 = 14$ $\frac{1}{2} \times 14 \times 28 = 196\text{cm}^2$</p> <p>c) $\frac{22}{7} \times 7 \times 7$ $= 22 \times 7 = 154$</p> <p>$\frac{1}{4} \times 28 \times 28 = 616$ $\frac{1}{2} + \frac{22}{7} \times 14 \times 14 = 308$</p> <p>$308 - 154 = 154$ $616 - 154 = 462\text{cm}^2$</p>						

17

a) $20 \div 8 = 2R4$

$7 + 15 \times 3 = \$52$

b) $\frac{1}{3} = \frac{3}{9}$ Ans : $\frac{2}{9}$

c) Donuts : $6 \times 8 = 48$

Cupcakes : $2 \times 5 = 10$

seriousaboutschoo.com