



AI TONG SCHOOL

**2023 PRELIMINARY EXAMINATION  
PRIMARY SIX SCIENCE**

**(BOOKLET A)**

**23 AUGUST 2023**

**Total time for booklets A and B : 1 h 45 min**

**INSTRUCTIONS**

1. Please check that your name, school and index number are printed **CORRECTLY** on the label.
2. Do not turn over this page until you are told to do so.
3. Follow all instructions carefully.
4. Answer all questions.
5. Use a dark blue or black ballpoint pen to write your answers in the space provided for each question.
6. Do not use correction fluid/tape or highlighters

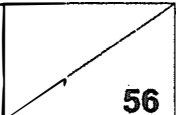
Booklet A	
-----------	---

**Parent's Signature :** \_\_\_\_\_

**Section A (28 x 2 marks)**

For each question from 1 to 28, four options are given. One of them is the correct answer. Make your choice and shade the correct oval (1, 2, 3 or 4) on the Optical Answer Sheet.

1. Judy found an animal in the forest.  
Which one of the following should she check to identify if the animal is an amphibian or a mammal?

- (1) The number of legs
- (2) The place they live in
- (3) The type of body covering
- (4) The method of reproduction

2. The diagram below shows the life cycle of a flowering plant.

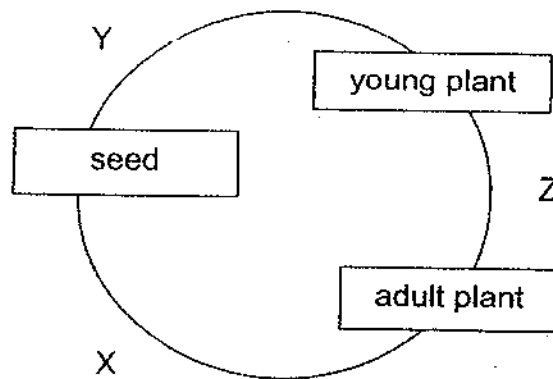

Which of the following statements is correct?

- (1) Pollination takes place at Z.
- (2) The flower develops into a fruit at X.
- (3) The plant does not need sunlight at X.
- (4) The male and female reproductive cells fuse at Y.

3. The diagram below shows the process of fertilisation taking place in humans.

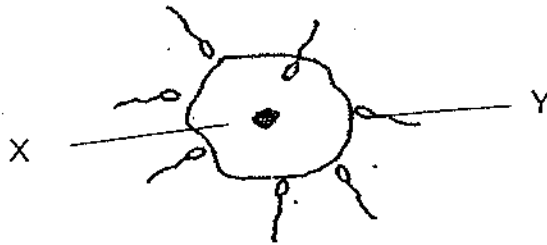

Which of the statement(s) about the process is/are true?

- A Y is produced in the testis.
- B X is produced in the womb.
- C One Y is needed to fertilise X.

- (1) B only
- (2) A and C only
- (3) B and C only
- (4) A, B and C

4. A fruit was cut open as shown below.

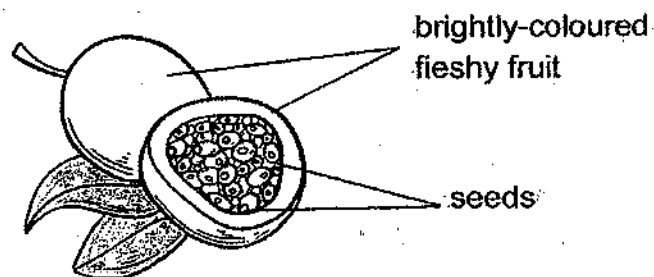

Which of the following statements are correct?

- A There were many ovaries in a flower.
- B The seeds could be dispersed by animals.
- C Pollination and fertilisation had taken place.
- D The fruit and seeds were developed from a flower.

- (1) A and B only
- (2) A and C only
- (3) B, C and D only
- (4) All of the above

5. Gary conducted an experiment on a plant that had been cut at points X and Y. At point X, both food-carrying tubes and water-carrying tubes were removed. At point Y, only the food-carrying tubes were removed.

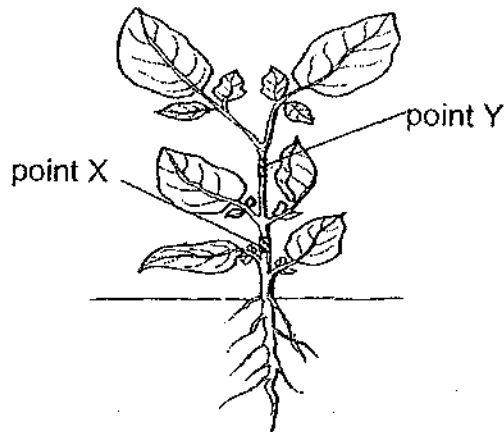

What would Gary likely observe after four days?

- (1) All the leaves would wither.
  - (2) Only leaves growing above point X would wither.
  - (3) Only leaves growing above point Y would wither.
  - (4) Only leaves growing between point X and point Y would wither.
6. The diagram below shows the human digestive system.

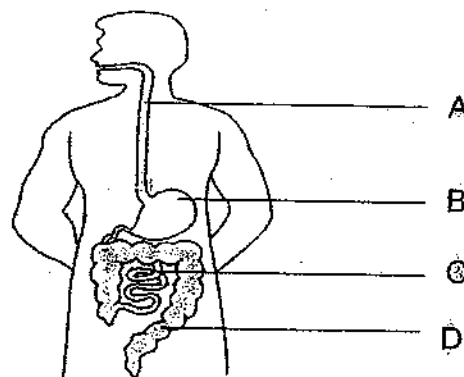

Which of the following correctly shows the change in the amount of digested food when it leaves parts A, B, C and D of the digestive system?

	No change	Increase
(1)	A	B
(2)	B	C
(3)	C	D
(4)	D	A

7. A few people were trapped in a lift during a blackout which caused the fan in the lift to stop working.

Which of the following shows the correct change in the amount of the components of air inside the lift after one hour?

- A Amount of nitrogen increases.
  - B Amount of oxygen decreases.
  - C Amount of water vapour increases.
  - D Amount of carbon dioxide stays the same.
- 
- (1) C only
  - (2) B and C only
  - (3) A, B and D only
  - (4) All of the above

8. The diagrams below show the circulatory systems of two organisms, a fish and a human. The arrows represent blood vessels carrying blood through various organs in the body.

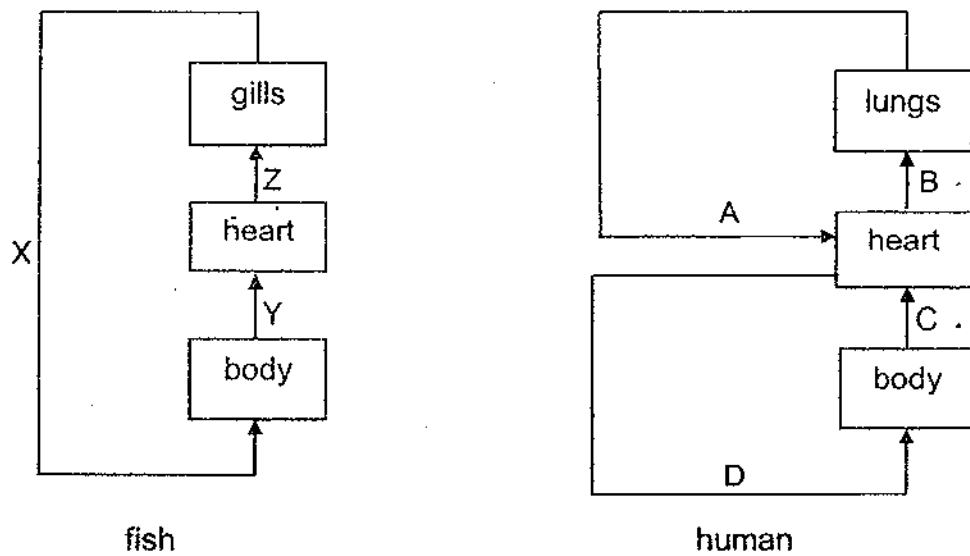

Based on the above diagrams, which of the following statement(s) is/are true?

- A Only blood vessels A, D and X carry oxygen-rich blood.
  - B Only blood vessels B, C, and Z carry blood that is rich in carbon dioxide.
  - C Both fish and human depend only on the heart to remove carbon dioxide from the body.
- (1) A only  
 (2) B only  
 (3) A and B only  
 (4) A, B and C

9. Ahmad classified three types of cells as shown below.

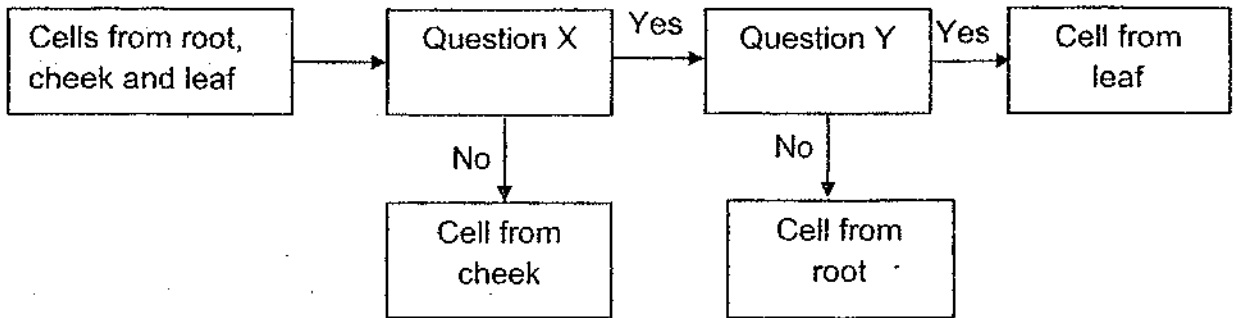

What could questions X and Y be?

	Question X	Question Y
(1)	Does the cell have a nucleus?	Does the cell have a cell wall?
(2)	Does the cell have chloroplasts?	Does the cell have a cell wall?
(3)	Does the cell have a cell wall?	Does the cell have chloroplasts?
(4)	Does the cell have cytoplasm?	Does the cell have cell membrane?

10. Study the food web below.

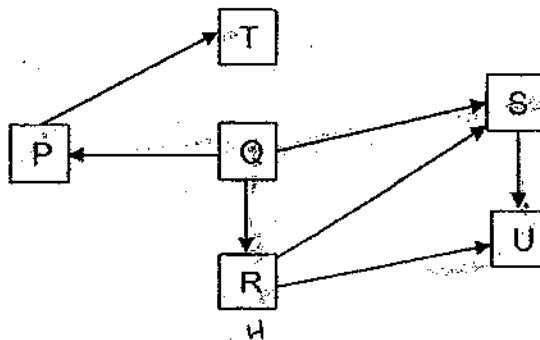

Which of the following statements is true?

- (1) Organism Q eats organisms P, R and S.
- (2) Organisms T and U are the only predators.
- (3) Organisms S and R eat both plants and animals.
- (4) Organisms in this food web can form more than three food chains.

11. A coin was placed at the bottom of a cylinder. Water taken from pond A was poured into the cylinder until the coin could no longer be seen. The height of the water  $h$  was measured.

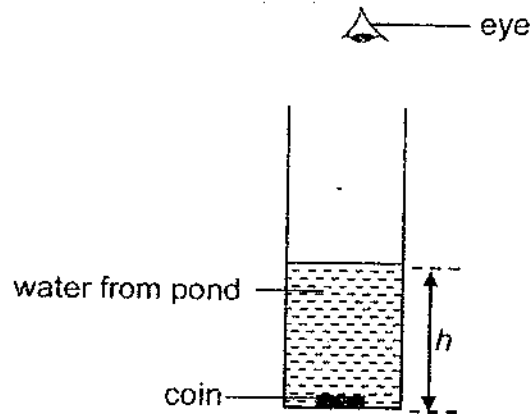

The experiment was repeated with water taken from ponds, B, C and D. The results are shown in the table below.

Ponds	$h$ (cm)
A	36
B	17
C	24
D	45

Based on the results above, which pond, A, B, C or D, would most likely have the least number of submerged plants?

- (1) A
- (2) B
- (3) C
- (4) D



12. The diagram below shows animal J.  
Animal J lives in the desert. It stays underground in the day and hunts for its prey at night when it is cooler.

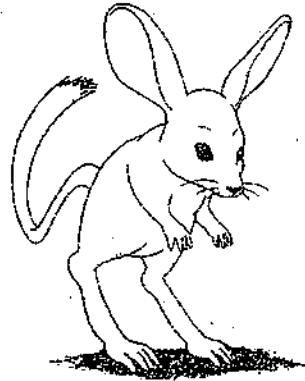

Based on the information given above, four students wrote the following statements about animal J.

Student	Features	Type of adaptation
Ali	Large ears with sensitive hearing	Behavioural adaptation
Bala	Stiff hairs on the soles of its feet	Structural adaptation
Chris	Move by hopping sideways	Structural adaptation
David	Hunts at night	Behavioural adaptation

Which students made the correct statement?

- (1) Ali and Chris only.
- (2) Bala and David only.
- (3) Ali, Bala and Chris only.
- (4) Bala, Chris and David only.

11. A coin was placed at the bottom of a cylinder. Water taken from pond A was poured into the cylinder until the coin could no longer be seen. The height of the water  $h$  was measured.

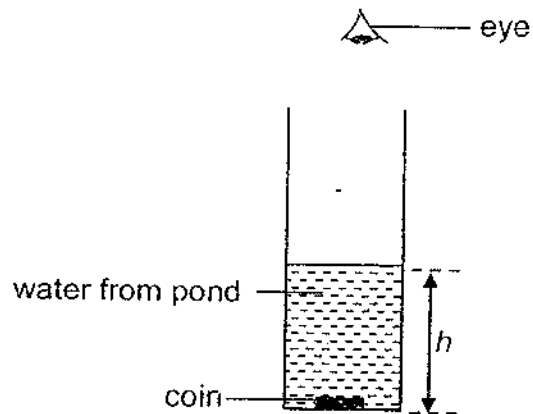

The experiment was repeated with water taken from ponds, B, C and D. The results are shown in the table below.

Ponds	$h$ (cm)
A	36
B	17
C	24
D	45

Based on the results above, which pond, A, B, C or D, would most likely have the least number of submerged plants?

- (1) A
- (2) B
- (3) C
- (4) D

12. The diagram below shows animal J.  
Animal J lives in the desert. It stays underground in the day and hunts for its prey at night when it is cooler.

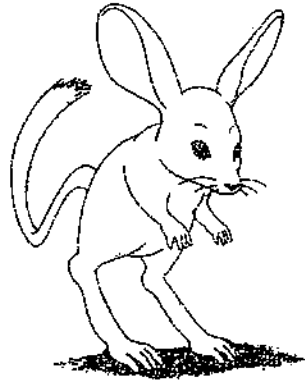

Based on the information given above, four students wrote the following statements about animal J.

Student	Features	Type of adaptation
Ali	Large ears with sensitive hearing	Behavioural adaptation
Bala	Stiff hairs on the soles of its feet	Structural adaptation
Chris	Move by hopping sideways	Structural adaptation
David	Hunts at night	Behavioural adaptation

Which students made the correct statement?

- (1) Ali and Chris only.
- (2) Bala and David only.
- (3) Ali, Bala and Chris only.
- (4) Bala, Chris and David only.

13. Jake plotted the graph below to show the amount of carbon dioxide that was released into the atmosphere in country X from 2018 to 2023.

Amount of carbon dioxide in the air (units)

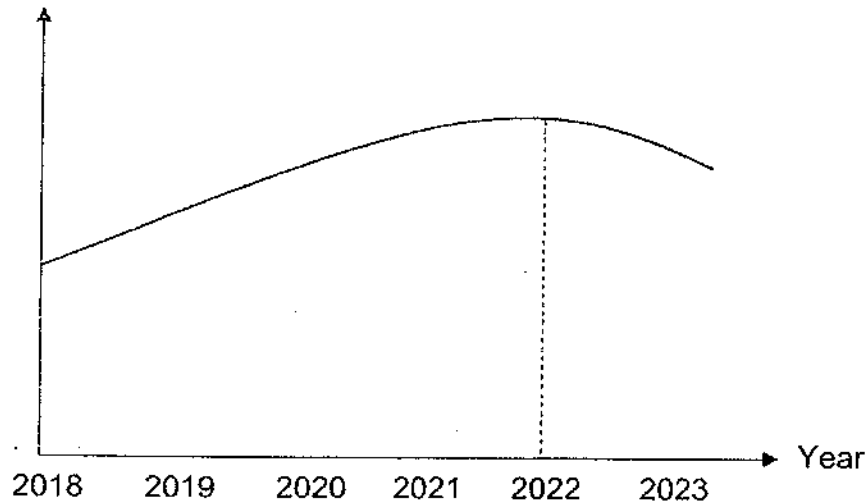

Based on the graph above, what could possibly cause the decrease in the amount of carbon dioxide in the air in country X from 2022 to 2023?

- A More people switched to taking public transport.
  - B More forests were cleared to build factories in the country X.
  - C Less waste was burned in the incinerator due to recycling efforts.
  - D There was more demand for air-conditioning due to the rising temperature in country X.
- (1) C only  
(2) A and C only  
(3) B and D only  
(4) All of the above

14. Plant A and Plant B are grown in two different locations. The graph below shows the amount of oxygen produced over a 24-hour period.

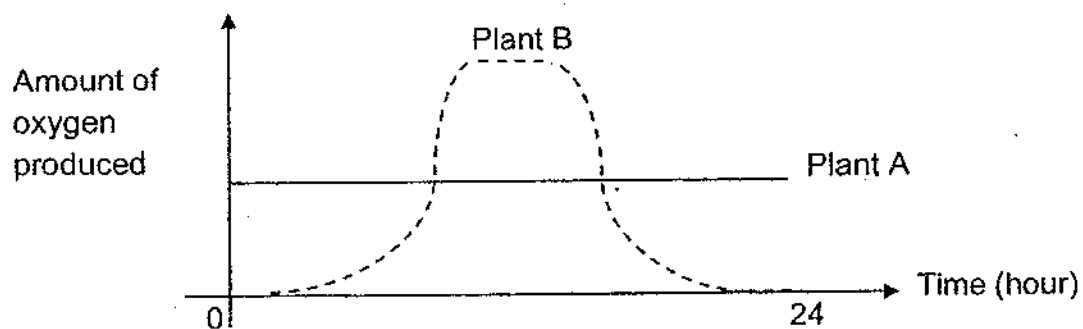

Based on the graph above, what conclusion can be made about both plants?

- (1) Plant B had more leaves than Plant A.
- (2) Only Plant B made food during the day.
- (3) Plant A was constantly exposed to light while Plant B was not.
- (4) Both plants A and B made food throughout the 24-hour period.

15. Chloe carried out the following experiment to find out which material, A, B, C or D, could be used to make a bath towel. She placed each material on top of four similar beakers as shown in the diagram below.

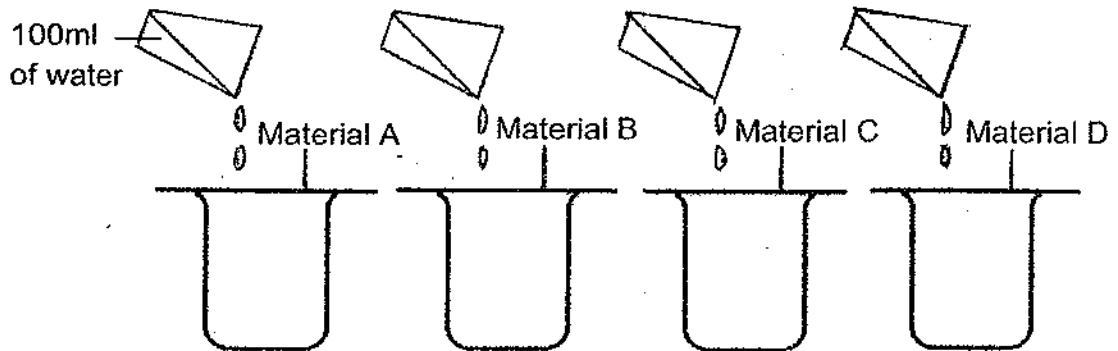

She then poured 100ml of water onto each material. The diagrams below show the results of the experiment.

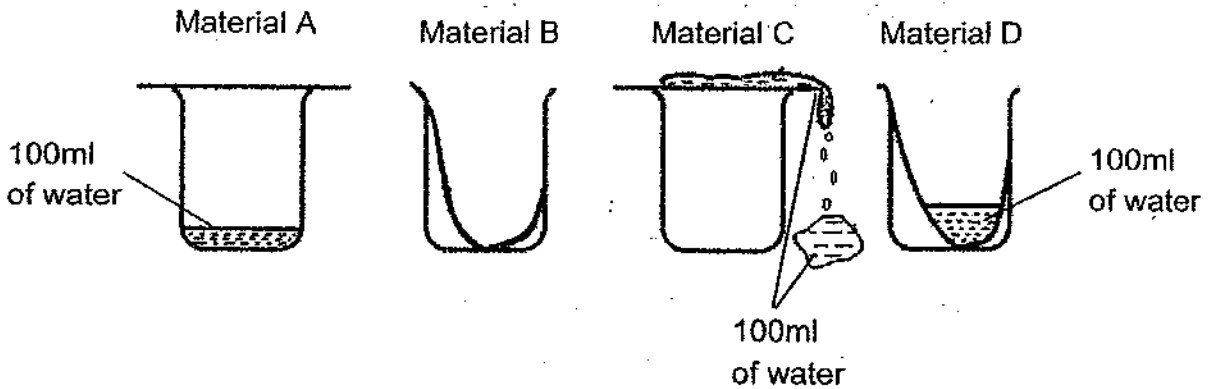

Which material, A, B, C or D is most suitable to be used for making a bath towel?

- (1) A
- (2) B
- (3) C
- (4) D

16. Ravi filled a 250 cm<sup>3</sup> measuring cylinder with water. He filled another 250 cm<sup>3</sup> measuring cylinder with marbles as shown below. Next, he transferred both the water and the marbles into a 1000 cm<sup>3</sup> measuring cylinder.

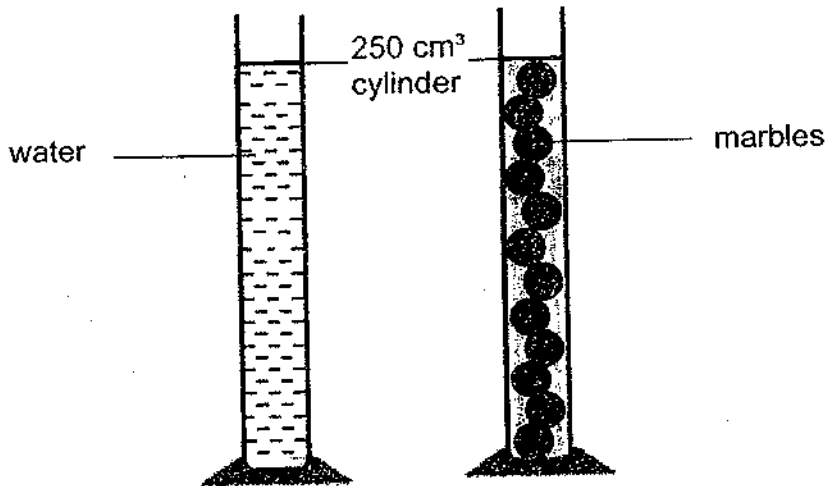

What would be the most likely volume occupied by the water and the marbles in the 1000 cm<sup>3</sup> cylinder?



- (1) 250 cm<sup>3</sup>
  - (2) 450 cm<sup>3</sup>
  - (3) 500 cm<sup>3</sup>
  - (4) 1000 cm<sup>3</sup>
17. Which of the following shows the correct comparison between boiling and evaporation of a liquid?

	Boiling	Evaporation
(1)	Liquid gains heat	Liquid loses heat
(2)	Occurs at a 100°C	Occurs at any temperature
(3)	Occurs throughout the liquid	Occurs at the surface of liquid
(4)	Liquid remains in the same state	Liquid changes to gaseous state

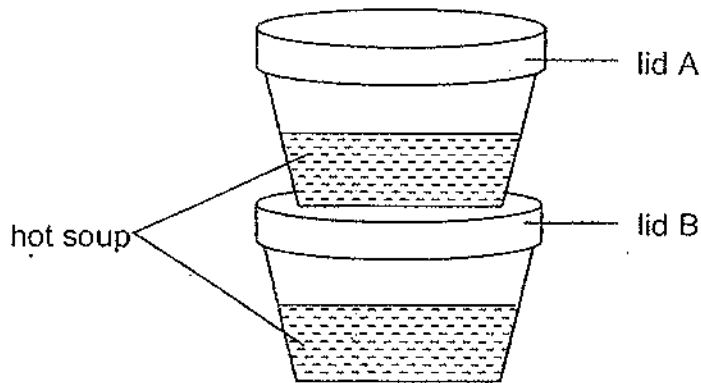
18. Mrs Tan bought two containers of steaming hot soup from the food court for dinner that evening. They were stacked on top of each other as shown in the diagram below.

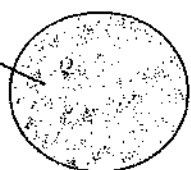

Mrs Tan found water droplets under each lid two hours later. Which of the following shows the water droplets that were formed under each lid after two hours?

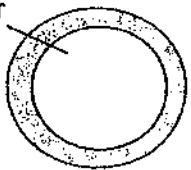
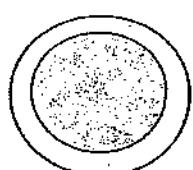
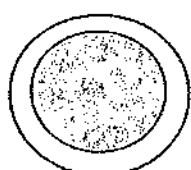
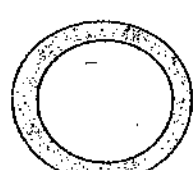
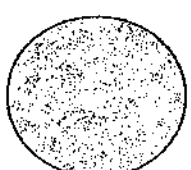
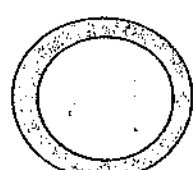
	Lid A	Lid B
(1)	water droplets 	
(2)	no water droplets 	
(3)		
(4)		



19. In the diagram below, box A contains matter A and box B contains matter B. Boxes A and B are of different sizes and thickness but made of the same material. Both boxes balance each other on a weighing scale as shown.

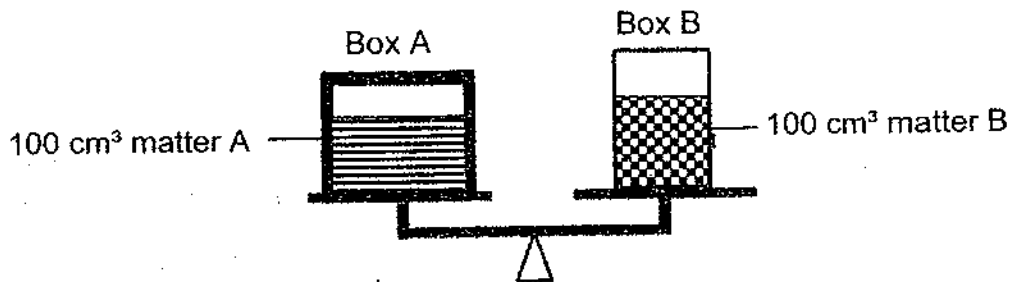

Based on the information given above, what can we conclude about matters A and B?

- A Matter A and B occupy space.
  - B Matter A and B have the same mass;
  - C Matter A and B have the same volume.
  - D Matter A and B cannot be compressed.
- (1) A and B only  
(2) B and C only  
(3) A, C and D only  
(4) All of the above.

20. Study the four circuits shown below. The bulbs and the batteries in the four circuits are identical. All the bulbs lit up.

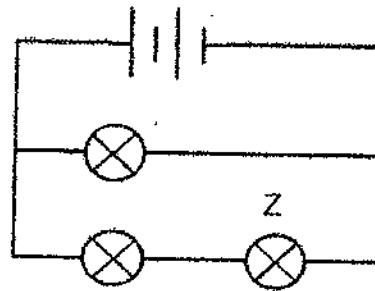
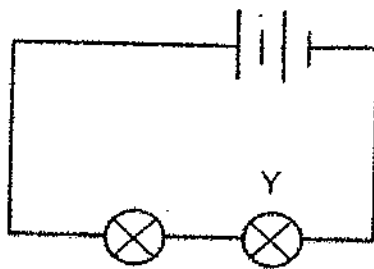
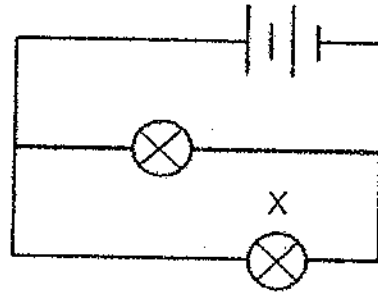
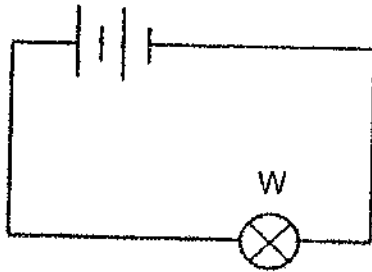

Which statement about the brightness of the bulbs is correct?

- (1) Bulb Z is as bright as bulb X.
- (2) Bulb Z is as bright as bulb W.
- (3) Bulb X is brighter than bulb Y.
- (4) Bulb X is brighter than bulb W.

21. Aileen had three rods P, Q, and R, of unknown materials. She placed them in various positions, A, B and C, as shown in the circuit below.

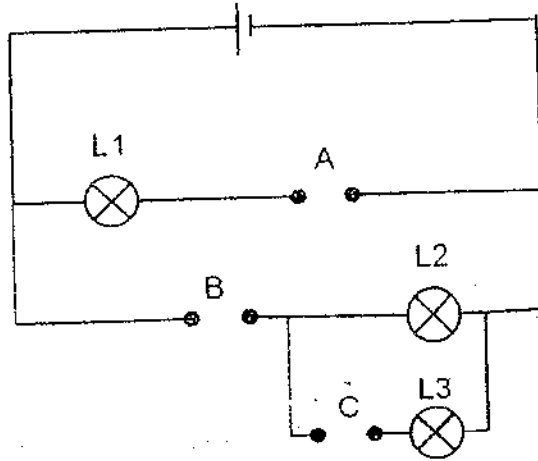

She observed if bulbs L1, L2 and L3 lit up and recorded her observations in the table below.

	Rod P	Rod Q	Rod R
Positions where rods were placed	A	B	C
Bulbs	L1	L2	L3
Did bulb light up?	No	Yes	Yes

She repeated the experiment by placing the rods at different positions as shown in the table below.

	Rod P	Rod Q	Rod R
Positions where rods were placed	B	A	C

Which one of the following would show the correct result?

	Would the bulb light up?		
	L1	L2	L3
(1)	Yes	Yes	No
(2)	Yes	No	No
(3)	No	Yes	Yes
(4)	Yes	Yes	Yes

22. Yong Le used the set-up shown below to find out the time taken for a wooden block to slide down two different surfaces, P and Q.

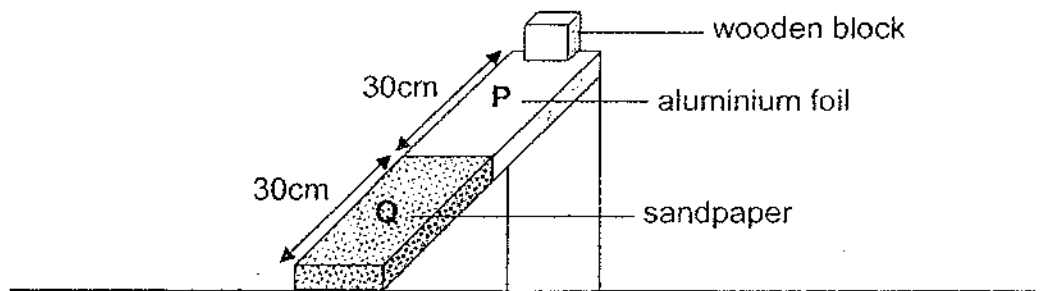

He measured the time taken for each wooden block to slide down the ramp and recorded the results in a graph.

Which one of the following graphs shows the most likely results obtained?

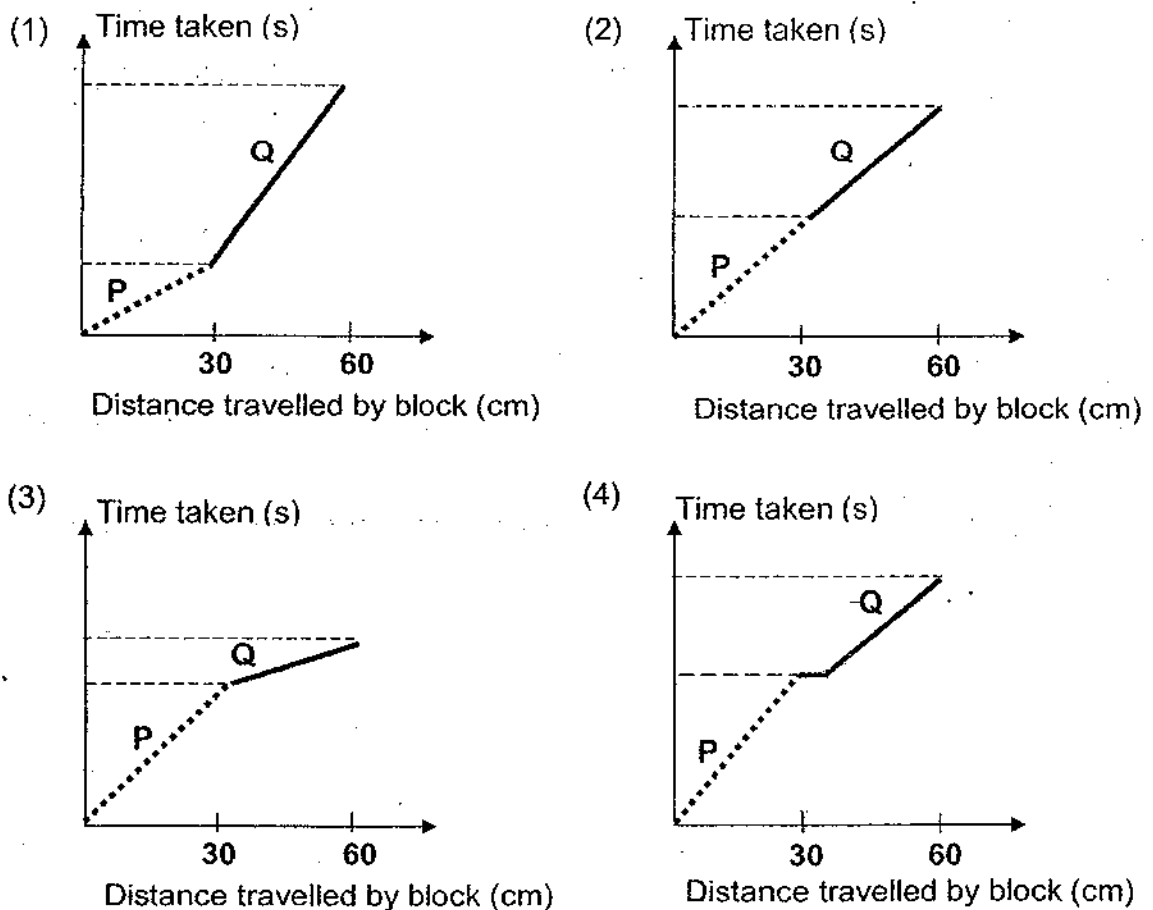

23. Andy went to an indoor flight chamber as shown below. When air was being blown in continuously from the bottom of the flight chamber, Andy was able to stay afloat at position W as shown.

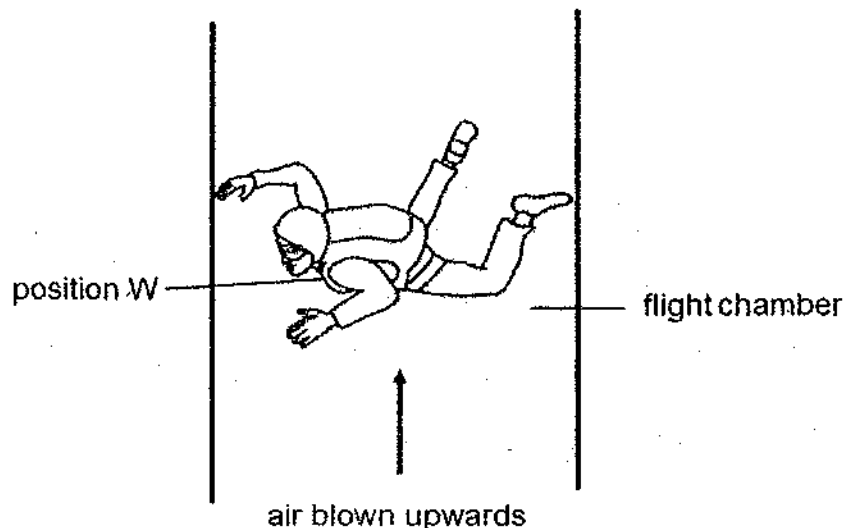

Which of the following best explains why Andy was able to stay afloat at position W?

- (1) The air trapped in Andy's clothes lifted him up and kept him afloat.
- (2) There was no gravitational force acting on Andy in the flight chamber.
- (3) The gravitational force acting on Andy was equal to the upward force exerted by the air blown at him.
- (4) The upward force exerted by the air blown at Andy is greater than his weight.

24. Gary has a toy which does not require any batteries to function.

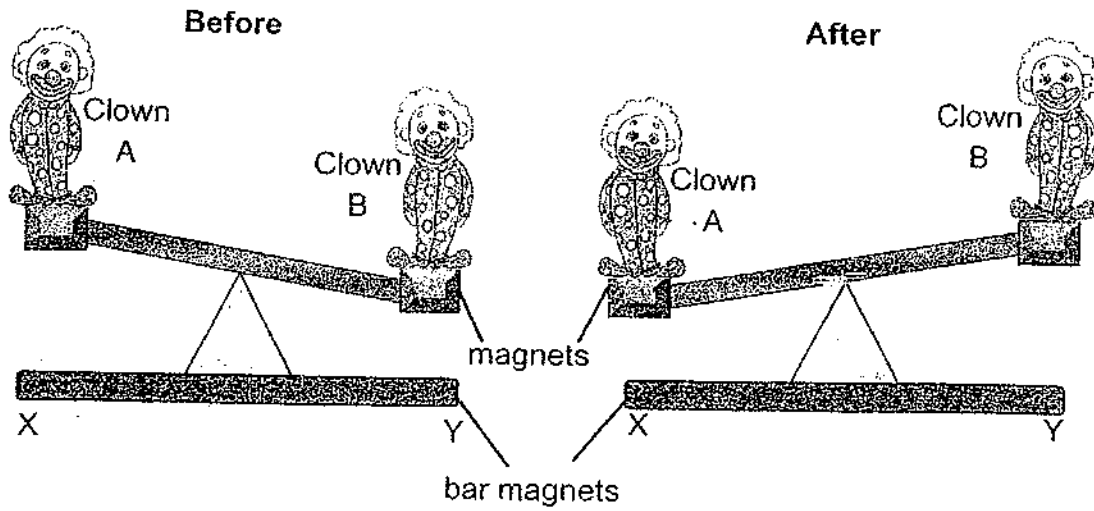



When clown B tilts downwards, it will soon move back up. The same action is observed in clown A. This process keeps repeating, resulting in both clowns moving up and down continuously.

Which of the following options correctly shows the poles of the magnets?

	X	Y	Clown A	Clown B
(1)	South	North	North	South
(2)	North	South	North	South
(3)	North	South	South	South
(4)	South	North	North	North

25. The table below shows the expansion of metals, K, L and M when they gain heat.

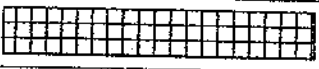
Key	Metal	Amount of expansion when they gain heat
	K	0.8 mm
	L	0.5 mm
	M	1 mm

Four containers were made with metals K, L, and M but their covers were mixed up. Water at 100°C was poured fully into the containers before they were covered and left standing for 10 minutes.

Which of the covers, A, B, C and/or D, will be difficult to remove from their containers after 10 minutes?

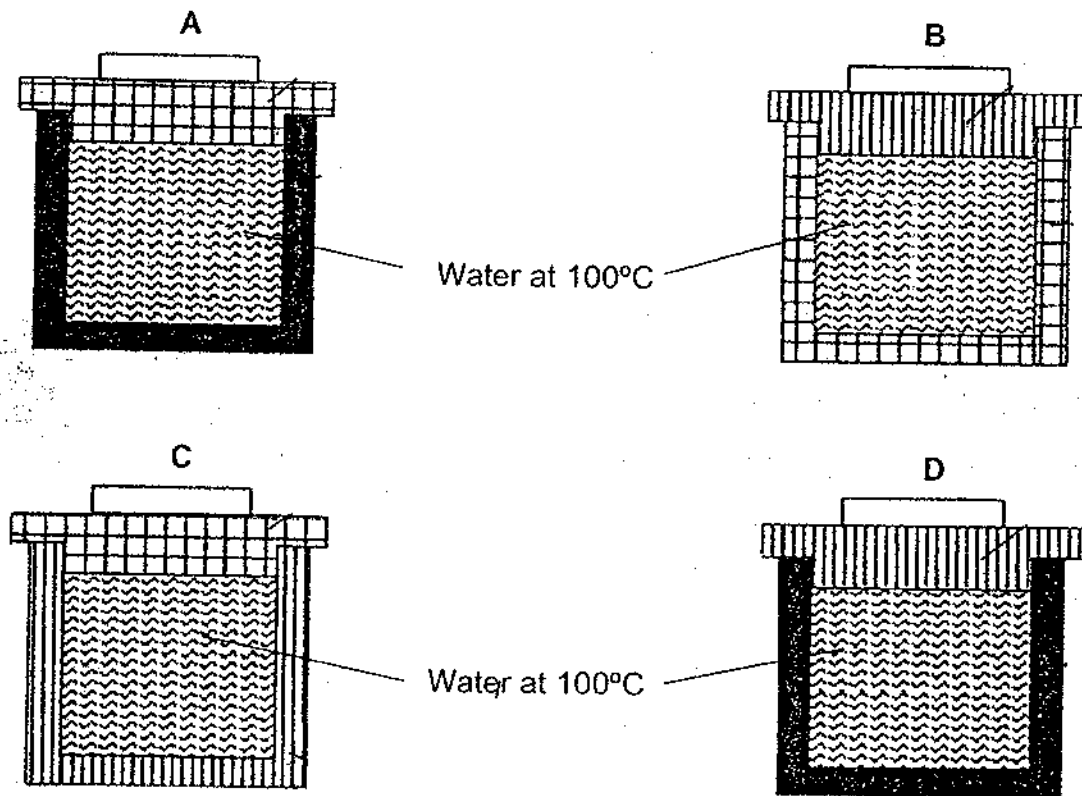

- (1) A and C only
- (2) A, B and D only
- (3) A, C and D only
- (4) B, C and D only

26. Brenda prepared a set-up with two torches and a cylindrical block. The diagram below shows the **top view** of the set-up.

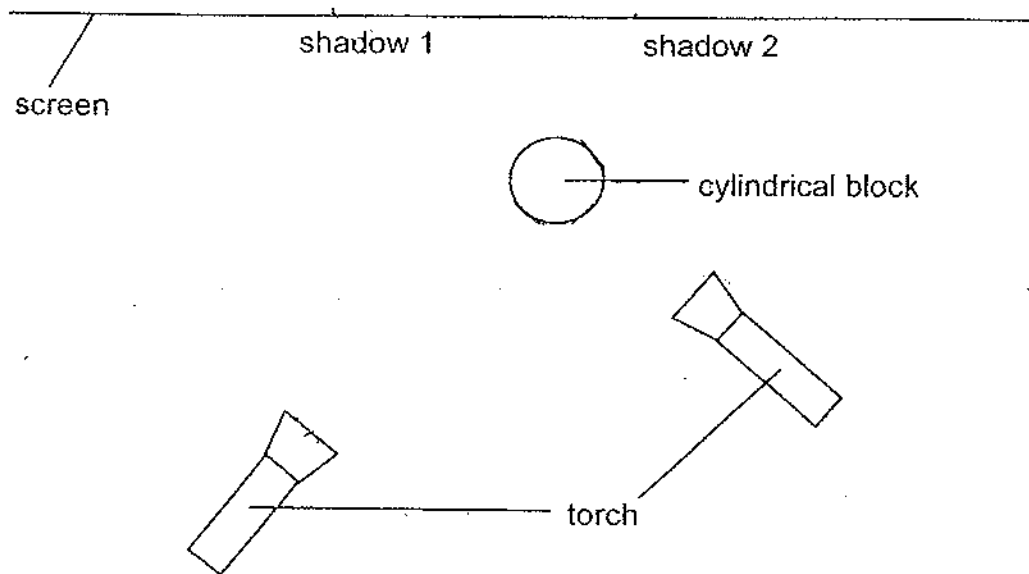

She turned on the torches and two shadows, 1 and 2, were cast on the screen.

Which one of the following correctly shows the shadows cast on the screen?

(1)

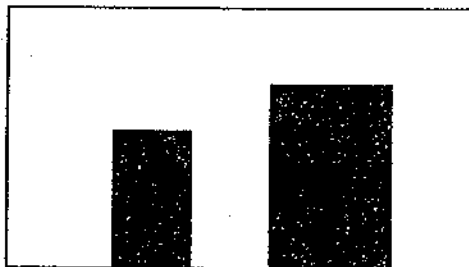

shadow 1 shadow 2

(2)

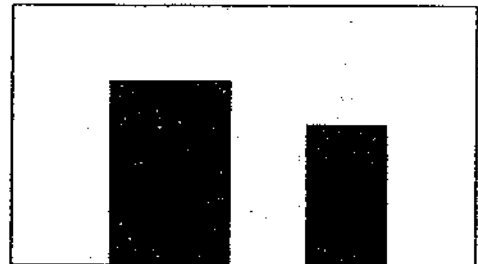

shadow 1 shadow 2

(3)

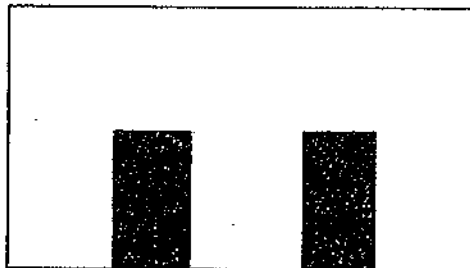

shadow 1 shadow 2

(4)

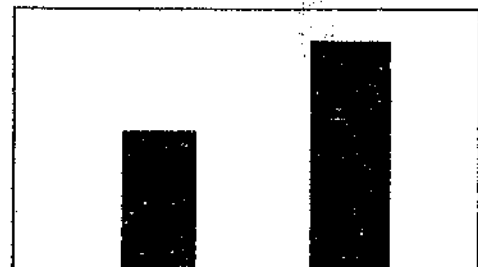

shadow 1 shadow 2



27 Study the flow chart below.

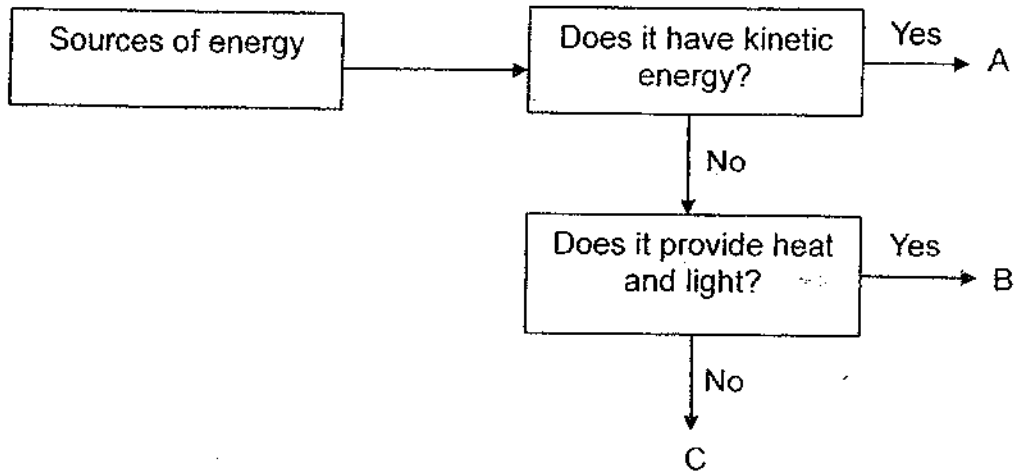

Which of the following correctly represents A, B and C?

	A	B	C
(1)	Wind	Sun	Burning of fuels
(2)	Running water	Wind	Stretched rubber band
(3)	Stretched rubber band	Sun	Wind
(4)	Running water	Burning of fuels	Stretched rubber band

28. The diagram below shows the movement of a basketball as it falls from position A, through the basket, hits the ground and bounces up again.

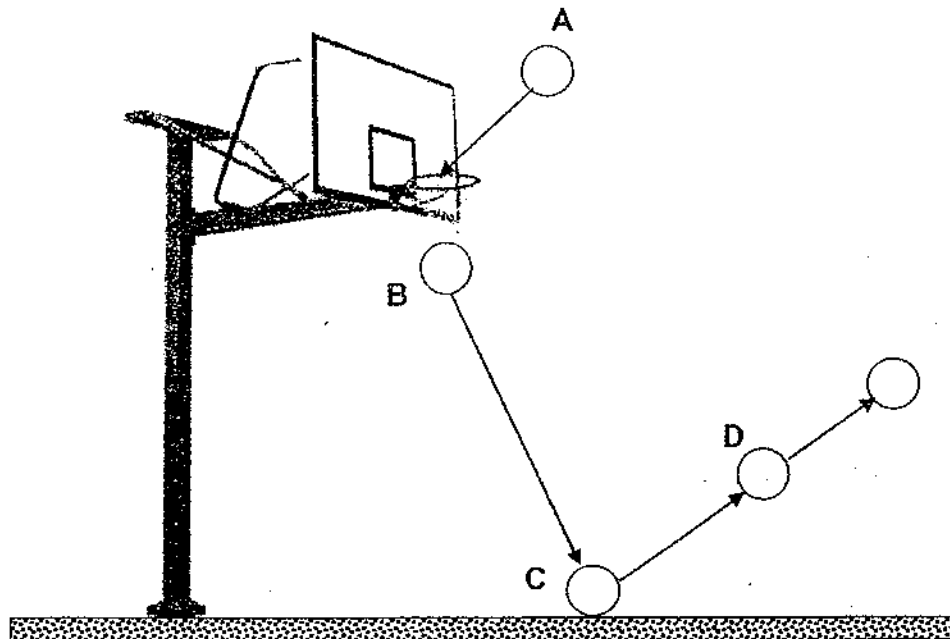

Which of the following statements are true?

- A Some of the energy was converted to heat and sound energy as the ball hit the ground at C.
- B Gravitational potential energy in the ball was converted to kinetic energy as the ball moves from A to B.
- C The gravitational force acting on the ball at D was less than the gravitational force acting on the ball at A.
- D The ball possessed no kinetic energy at position D.

- (1) A and B only
- (2) C and D only
- (3) A, B and C only
- (4) A, B and D only

**End of Booklet A**



AI TONG SCHOOL

2023 PRELIMINARY EXAMINATION  
PRIMARY SIX SCIENCE

(BOOKLET B)

23 AUGUST 2023

Total time for booklets A and B : 1 h 45 min

**INSTRUCTIONS**

1. Please check that your name, school and index number are printed **CORRECTLY** on the label.
2. Do not turn over this page until you are told to do so.
3. Follow all instructions carefully.
4. Answer all questions.
5. Use a dark blue or black ballpoint pen to write your answers in the space provided for each question.
6. Do not use correction fluid/tape or highlighters

Booklet B	44
-----------	----

Parent's Signature : \_\_\_\_\_

**Section B: 44 marks**

Read the questions carefully and write down your answers in the spaces provided.

29. The diagram below shows the development of a human baby.

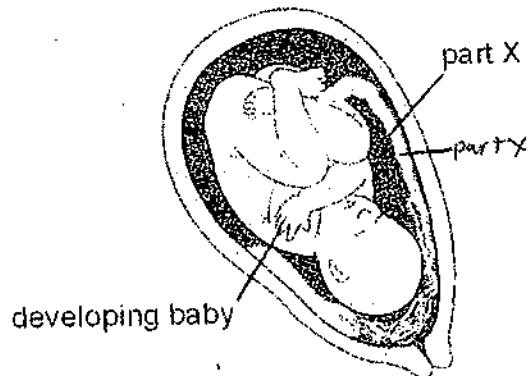

(a) State the function of part X. [1]

---

---

(b) State the part of the human body where the developing baby will be at. [1]

---

(Go on to the next page.)

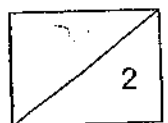

30. Alvin put some dead leaves and a small amount of damp soil in a glass jar as shown below.

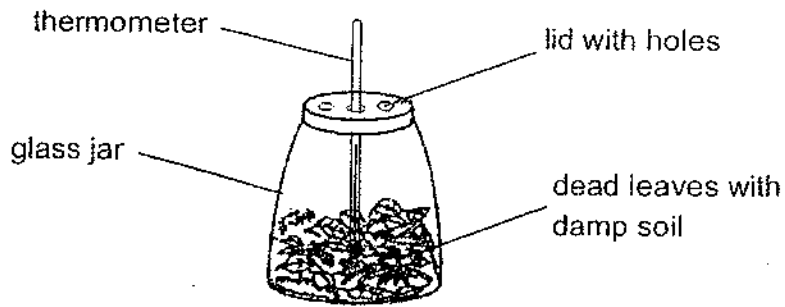

He used a thermometer to measure the change in temperature as the leaves decay over a period of time.

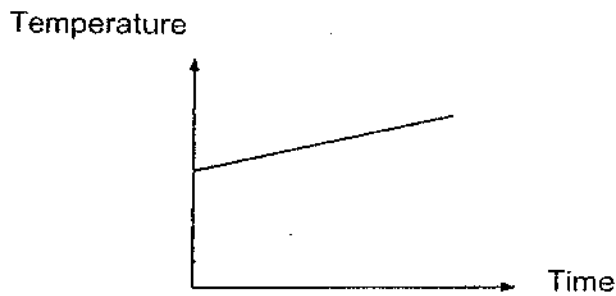

(a) State two conditions needed for decomposition to take place. [1]

---

---

(b) State two products that are given out during decomposition. [1]

---

---

Question 30 continues on the next page.

(Go on to the next page.)

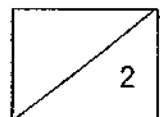

Bird Z buries its eggs underground. The eggs are placed on top of decaying leaves and covered with sand.

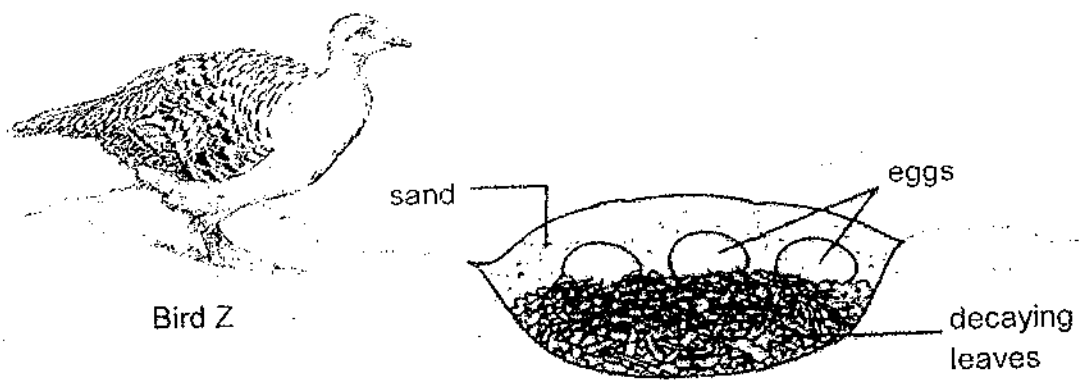

(c) Based on Alvin's experiment, explain why the bird lays its eggs underground, on top of the decaying leaves. [1]

---

---

(d) Suggest another advantage of burying eggs underground. [1]

---

---

(Go on to the next page.)

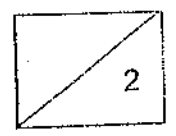

31. Eric placed four plants in identical jars, each containing water at the same level as shown below.

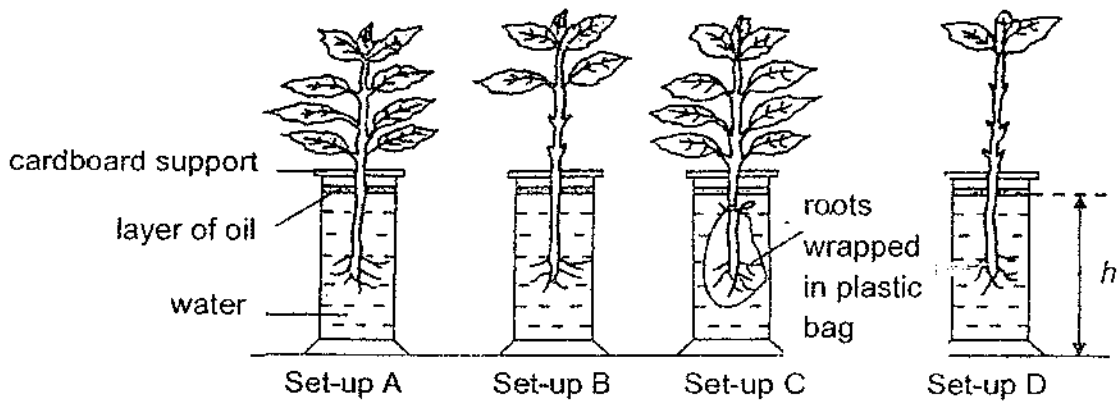

He then placed the four set-ups A, B, C and D next to a window for two hours.

At the end of two hours, Eric measured the height  $h$  in each jar. He recorded the following heights  $h$  in the table below.

Height $h$ (mm)	Set-up
200	
190	
185	
175	

(a) Complete the table above to show the correct results of the experiment. [1]

(b) Which two set-ups should he compare to show that the roots of a plant absorb water? [1]

---

(c) If set-up C was removed, leaving only set-ups A, B and D, what would be the aim of Eric's experiment? [1]

---



---

(Go on to the next page.)

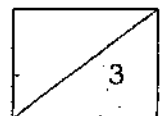

32. The diagram below shows the human digestive system.

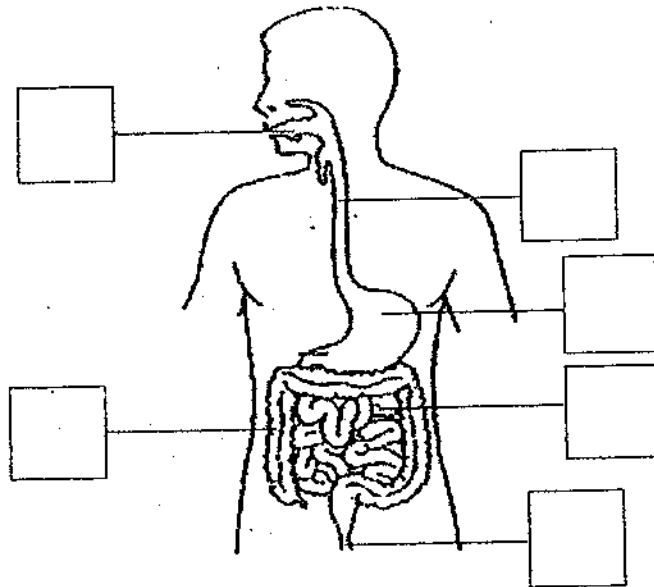

- (a) Write the letter **N** in the box to indicate the part where food is broken into smaller pieces, and the letter **W** to indicate the part in which water is absorbed from undigested food. [1]
- (b) Describe how the digestive system works together with the circulatory system in our body. [2]

---

---

---

(Go on to the next page.)

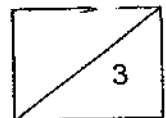



33. Organism C is a small transparent animal found in the ocean. It feeds on microscopic plants and animals.

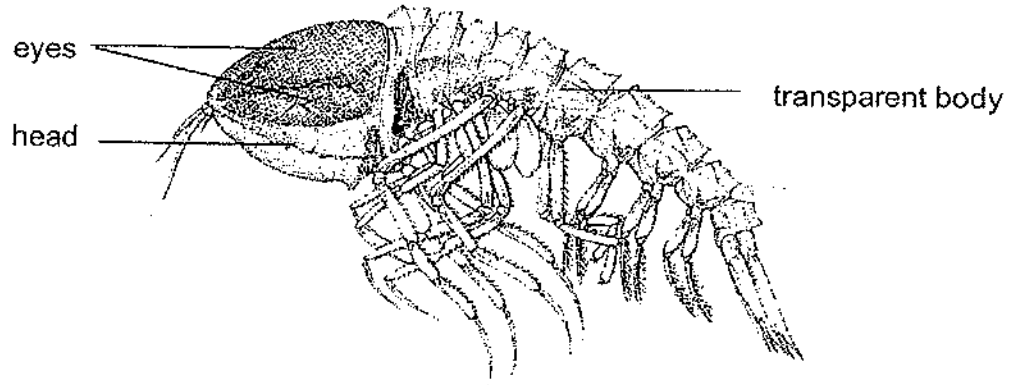

- (a) How does the transparent body of Organism C help it to survive in the ocean? [1]

---

---

- (b) Organism C has very special eyes that occupy almost the entire head. They are spread out into a thin sheet of tiny reddish dots that are too small to be seen by other animals.

- (i) Name the type of adaptation mentioned above. [1]

---

- (ii) How does this adaptation allow organism C to see more clearly in the dim ocean water? [1]

---

---

(Go on to the next page.)

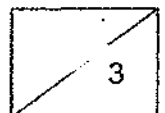

34. In country X, a farmer, Mr James, grew plant A in a greenhouse. He found out that to get sweeter fruits of plant A, the plant must be exposed to at least six hours of sunlight daily.

(a) Suggest how having at least six hours of sunlight daily would help in producing sweeter fruits. [1]

---

---

(b) Next to Mr James' greenhouse is a power station. There are pipes to transport the carbon dioxide produced by the power station to the greenhouses around the area. How does this arrangement benefit Mr James' plants and the environment? [2]

(i) Benefit to Mr James' plants:

---

---

(ii) Benefit to the environment:

---

---

(Go on to the next page.)

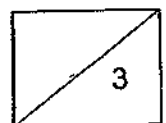

35. The diagram below shows an ice-cream maker designed by Mr Wong. He wants to turn liquid M into ice-cream.

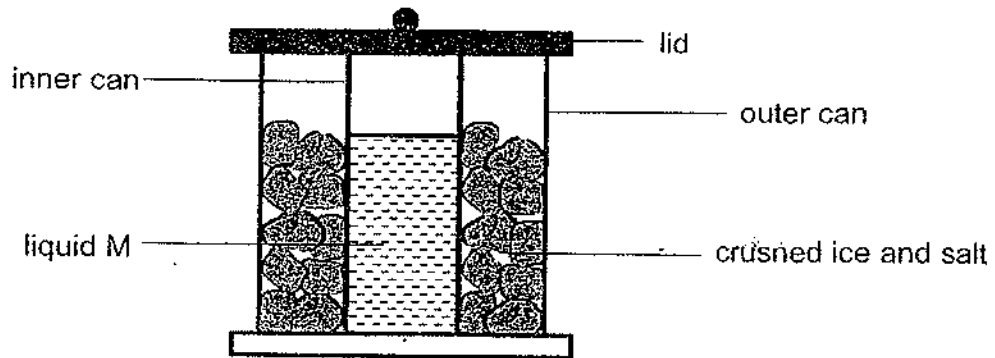

To find out which materials are suitable for making the inner and outer can, Mr Wong tested materials A and B.

He poured the same amount of ice into two containers made of material A and B in set-ups 1 and 2 respectively. Then he placed them on a thin layer of water.

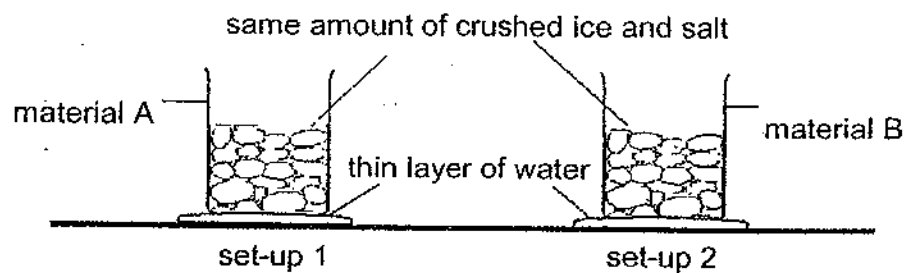

He observed that the layer of water in set-up 1 froze after 3 minutes while the layer of water in set-up 2 froze after 7 minutes.

- (a) From the results of the test, which material, A or B, should Mr Wong use for making the inner and outer cans of his ice-cream maker? [1]

Inner can: \_\_\_\_\_

Outer can: \_\_\_\_\_

- (b) Explain your choices in part (a). [2]

---



---



---

(Go on to the next page.)

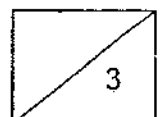

36. Fill in the boxes below with the correct states of matter.

[1]

(a)

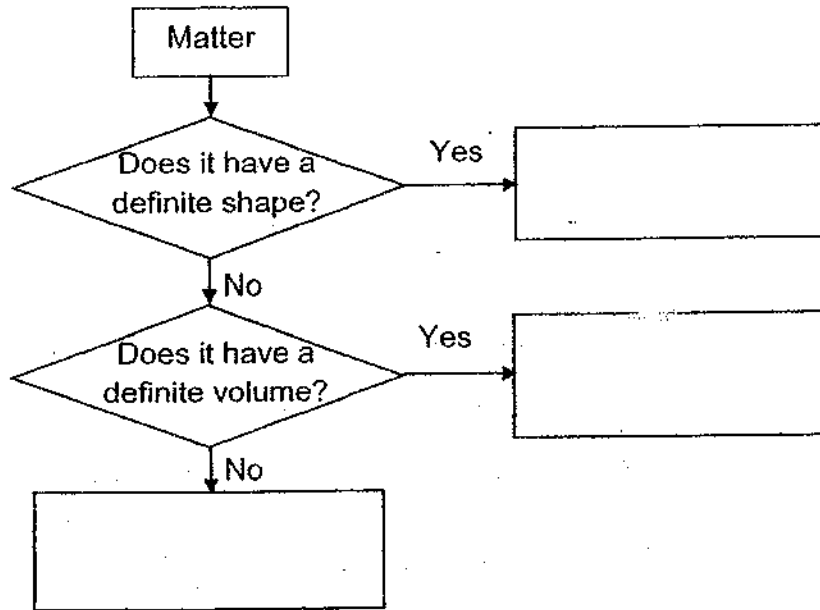

The tanks shown below are used to store Gas H, which is used to inflate balloons.

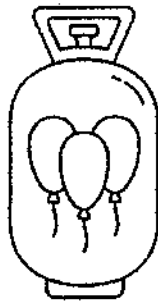

**Tank A**  
Inflates 50 balloons

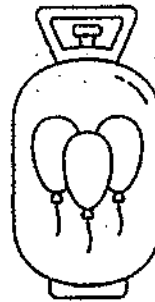

**Tank B**  
Inflates 55 balloons

Two identical tanks containing the same volume of gas H are used to inflate identical balloons to the same size for a party. Tank A can inflate 50 balloons while Tank B can inflate 55 balloons.

(b) Explain why the same volume of gas H can inflate a different number of balloons. [2]

---

---

---

(Go on to the next page.)

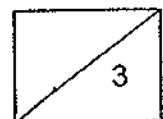

37. Mr Tay designed a candy dispenser shown below to dispense a fixed amount of candies for his customers. When the switch is closed, the moveable steel rod springs open and a fixed amount of candies drops from the container into the tray.

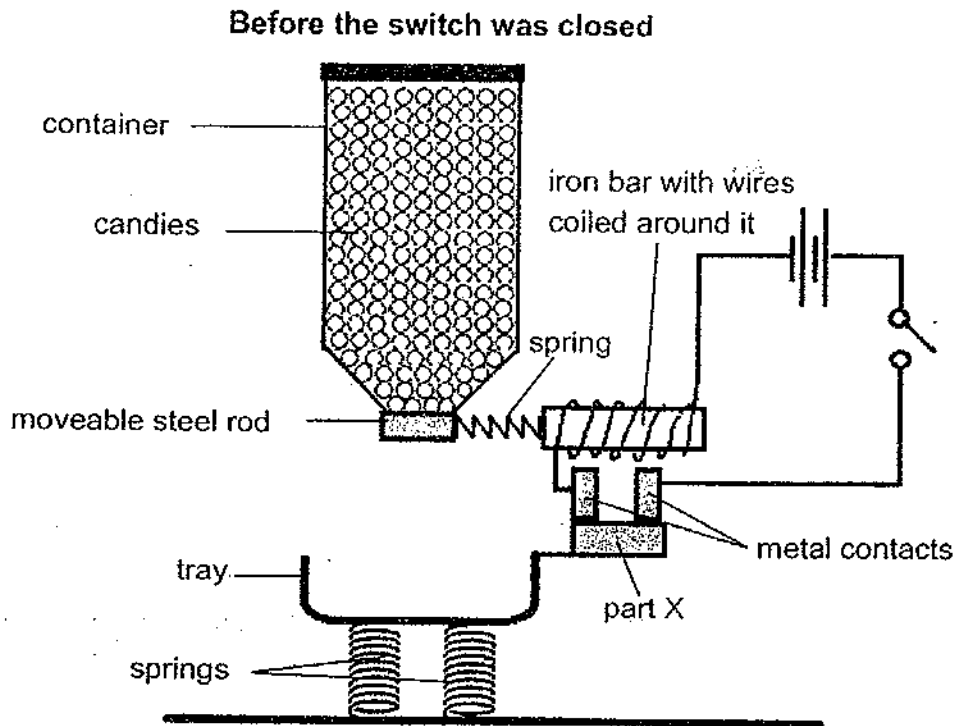

**After candies are dispensed**  
The metal rod then automatically springs back and stops candies from being dispensed.

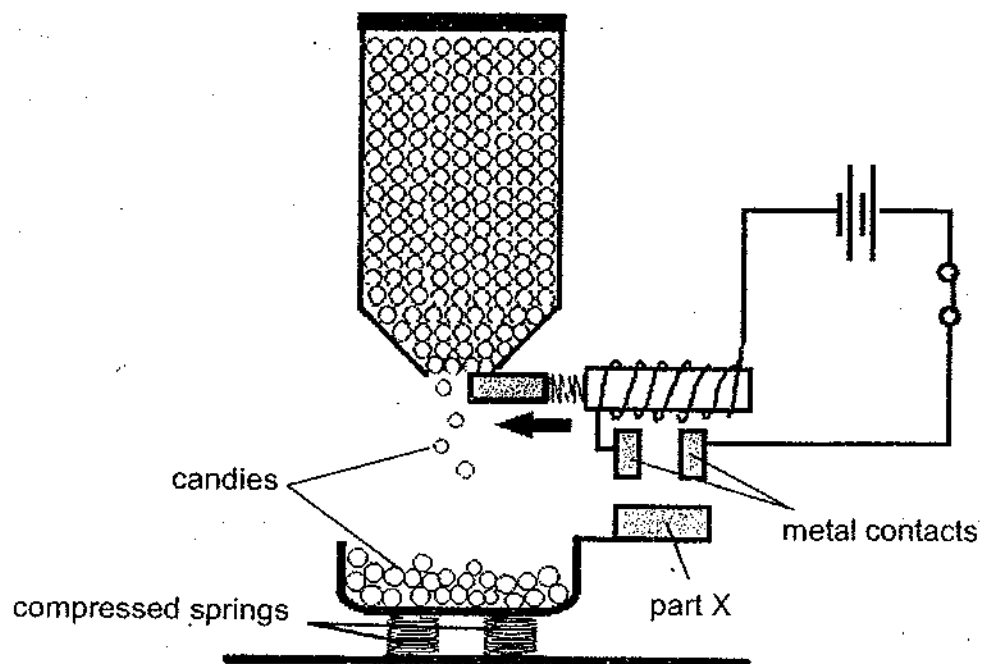

- (a) State a property of the material used to make part X so that this candy dispenser can work properly. [1]

---

- (b) Explain how the setup allows candies in the container to drop into the tray when the switch is closed. [2]

---

---

---

---

- (c) How do the candies in the tray cause an open circuit? [1]

---

---

- (d) Suggest one change to the set-up so that fewer candies could be dispensed into the tray each time. [1]

---

---

(Go on to the next page.)

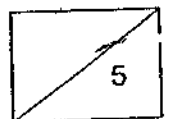

38. Gopal prepared set-ups A, B and C as shown below. Equal volume of air, water and iron filings were placed in the test-tubes and heated for 6 minutes.

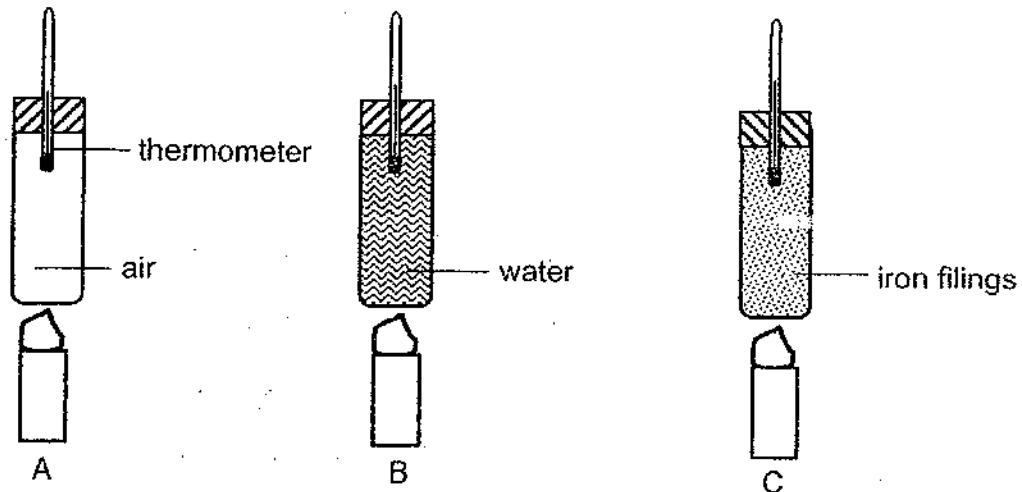

The changes in the temperature of the content in the test-tubes were recorded in the table below.

Time / minutes	Temperature of substance in test-tube in set-up (°C)		
	A	B	C
0	32	30	27
3	37	46	59
6	42	64	90

- (a) Based on the information above, what can Gopal conclude about the heat conductivity of air and iron? Explain your answer. [2]

---



---



---

- (b) Gopal's teacher told him his experiment was not a fair one. What should Gopal do to make it a fair test? [1]

---



---

(Go on to the next page.)

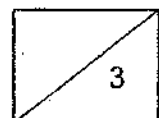

39. Leon conducted another experiment using two identical tin cans as shown below. Can A was painted white and Can B was painted black. Both cans were filled with  $200 \text{ cm}^3$  of water at  $25^\circ\text{C}$ . He placed both cans under the sun.

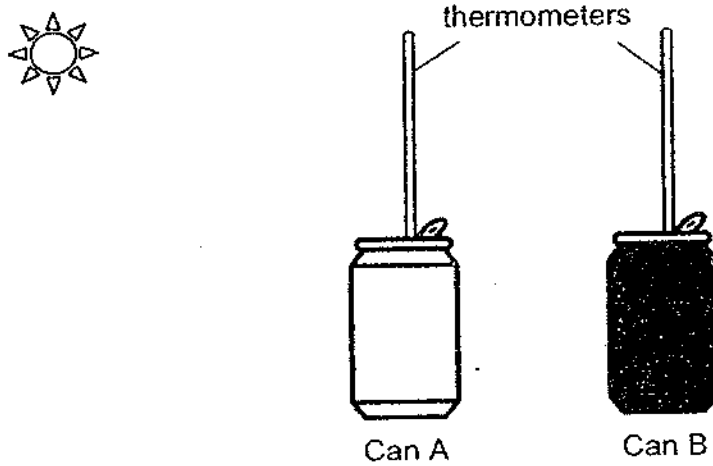

He recorded the temperature of water in both cans over a period of time. His results are shown in the graph below.

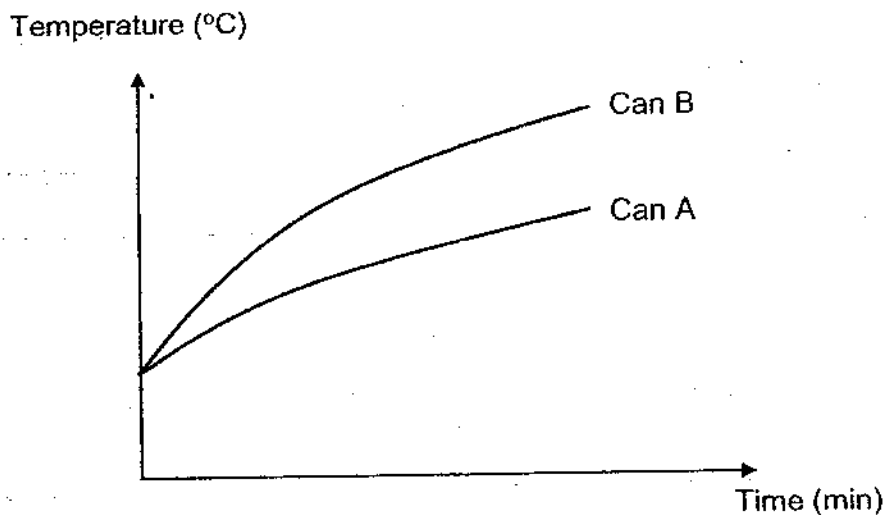

- (a) Based on Leon's results, which can, A or B, absorbed more heat? Explain your answer. [1]

---

---

(Go on to the next page.)

Question 39 continues on the next page:

B-13

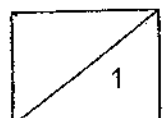



Next, Leon set up the following models to collect pure water from sea water. He wanted to find out which set-up would be able to collect more pure water. He placed both set-ups in the field under the sun for two hours.

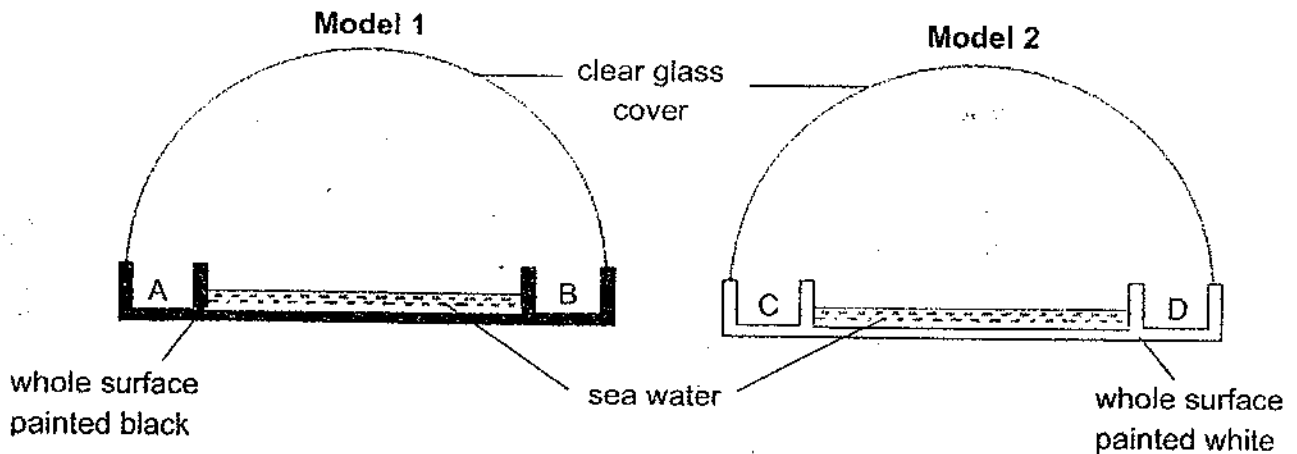

(b) Explain how pure water is collected in A, B, C and D. [2]

---

---

---

(c) Which model, 1 or 2, will collect more water at the end of the experiment? Explain your answer. [1]

---

---

(Go on to the next page.)

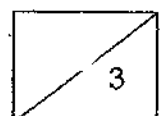

40. Rafi attempted to jump over three oil barrels on his skateboard. First, he balanced himself at the edge of the top of the ramp. Next, he moved down the ramp as shown in the diagram below. He took off into the air when he reached the end of the ramp.

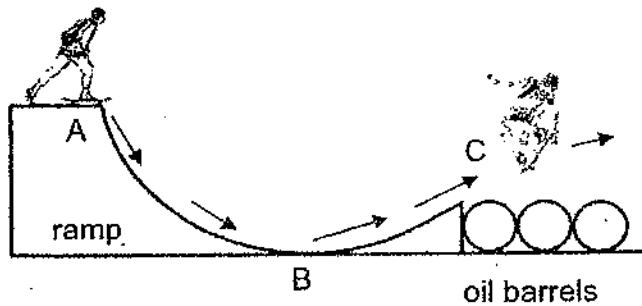

- (a) State the energy conversion that took place from point A to point C. [1]

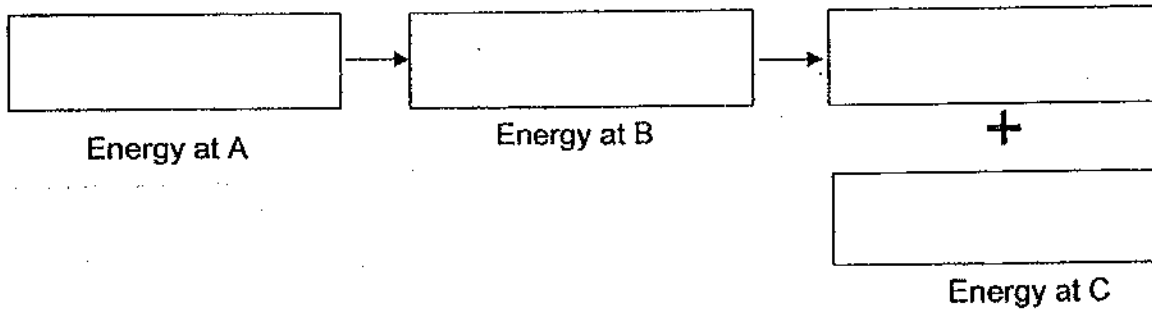

Question 40 continues on the next page.

(Go on to the next page.)

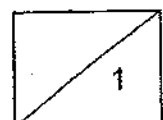

Rafi succeeded in jumping over three oil barrels and he wanted to challenge himself to jump over six barrels on his skateboard. He extended the ramp to go further and higher.

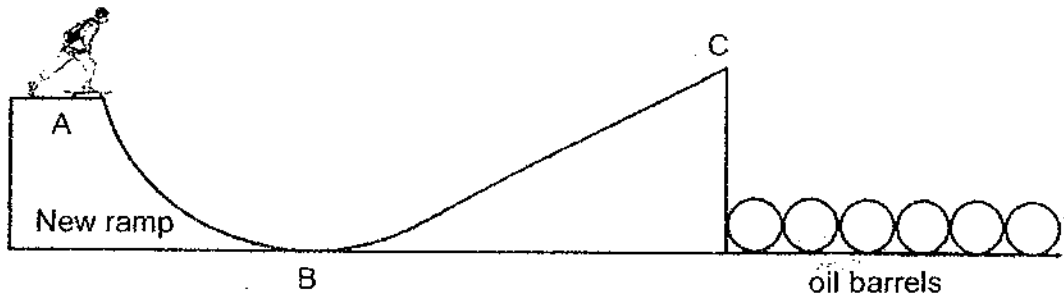

- (b) Explain why Rafi would not succeed. [2]

---

---

---

- (c) To solve the problem, Rafi applied a thin coat of oil on the ramp and tried again. Give a reason why he was able to reach a higher height than in part (b). [1]

---

---

- (d) What could Rafi do to jump successfully over the six barrels using the same ramp in part (b)? [1]

---

---

(Go on to the next page.)

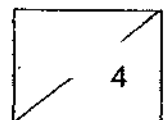

41. The diagram below shows a man using a bow and an arrow to hit a target at a distance. Once he releases the bow, the arrow will move forward.

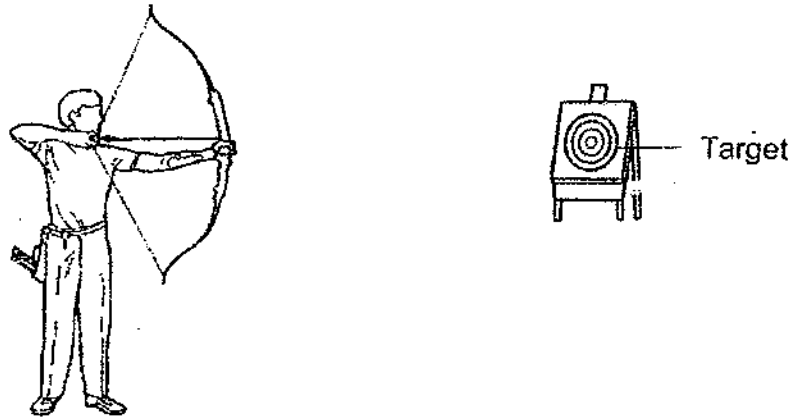

- (a) What is the effect of the force exerted on the arrow? [1]

---

---

- (b) The target was moved further away from the man. Without changing his standing position, what should the man do to hit the target using the same bow and arrow? Explain in terms of forces. [2]

---

---

---

**End of paper.**

**Please check your answers**

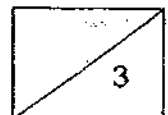

EXAM PAPER 2023

LEVEL : PRIMARY 6  
 SCHOOL : AI TONG SCHOOL  
 SUBJECT : SCIENCE  
 TERM : PRELIMINARY EXAMINATIONS

Q1	Q2	Q3	Q4	Q5	Q6	Q7	Q8	Q9	Q10
3	2	2	3	2	1	2	1	3	4
Q11	Q12	Q13	Q14	Q15	Q16	Q17	Q18	Q19	Q20
2	2	2	3	2	2	3	4	3	3
Q21	Q22	Q23	Q24	Q25	Q26	Q27	Q28		
2	1	3	2	3	2	4	1		

- Q29 a) To transport oxygen, water and digested food to the baby / transport waste materials from the baby to the mother.  
 b) Womb / Uterus

- Q30 a) Oxygen / warmth / water  
 b) Carbon dioxide and nutrients  
 c) The heat produced when the leaves decay keeps the eggs warm to hatch them.  
 d) Protect the eggs from predators

- Q31. a) C, D, B, A  
 b) Set-ups A and C  
 c) To find out if the number of leaves will affect the amount of water absorbed by the roots for the plants.

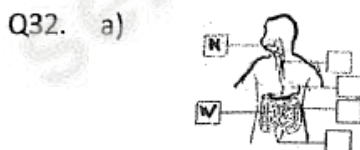

- b) Food digested in the digestive system is absorbed into the bloodstream at the small intestine. The circulatory system transports the blood carrying the digested food to all parts of the body.
- Q33. a) The transparent body cannot be seen by its predators, so it cannot be easily caught or eaten.
- b) (i) Structural adaptation  
 (ii) The eyes can receive more light to enable organism C to see more clearly.

- Q34 a) With more exposure to sunlight, plant A can trap more light to make more food, so fruit A will be sweeter.  
 b) (i) With carbon dioxide provided, the plants in the greenhouse can photosynthesize.  
 (ii) Air pollution is reduced / Reduce global warming
- Q35 a) Inner can: Material A / Set-up 1  
 Outer can: Material B / Set-up 2  
 b) The inner can should be able to lose heat faster to freeze liquid M faster. The outer can should gain heat slower from the surrounding so that the ice melts slower.
- Q36 a) (i) Solid  
 (ii) Liquid  
 (iii) Gas  
 b) Gas H has no definitive shape. The gas in tank B is more compressed than the gas in tank A
- Q37 a) Conductor or electricity  
 b) When the switch is closed, a closed circuit is formed. The iron bar becomes an electromagnet and attracts the steel rod. This allows the candies to drop onto the tray.  
 c) When the tray is filled with candies, it becomes heavier and the spring will be compressed. Part X will no longer touch the metal contacts, forming an open circuit.  
 d) Use springs that compress more easily / Replace the tray with a heavier one.
- Q38. a) Iron is a better conductor of heat than air. The temperature of the iron fillings increased faster than the temperature of the test tube containing air. —  
 b) He should ensure that the temperature of air, water and iron fillings are the same at the start of the experiment.
- Q39. a) Can B. The temperature of the water in can B increases more than in can A over the same period of time.  
 b) The water in the seawater gained heat from the sun and evaporated. The warmer water vapour touched the cooler surface of the glass cover, lost heat and condensed into water droplets, which flowed down into A,B,C and D.  
 c) Model 1. The black painted surface in model 1 gained heat faster from the surrounding air than white colour, so the water will evaporate faster and condense faster on the glass cover in model 1 than in model 2.
- Q40 a) Potential energy → Kinetic energy → Potential energy + Kinetic energy  
 b) Point C is higher than where he started from. He will not have enough gravitational potential energy to convert to kinetic energy to reach point C.  
 c) The layer of oil will reduce friction between his skateboard and the ramp.  
 d) He could apply a push force as he comes down the ramp.
- Q41 a) The force caused the stationary arrow to move forward.  
 b) He must pull the string on the bow further back. This increases the elastic spring force exerted on the arrow, moving it further.