

**Temasek Primary School**  
**Preliminary Examination**  
**Primary Six Standard**  
**2023**  
**SCIENCE**  
**(BOOKLET A)**

Name: \_\_\_\_\_ ( ) Class: 6

Date : 24 August 2023

Total Time for Booklet A and B : 1 hour 45 minutes

**INSTRUCTIONS TO CANDIDATES**

1. Do not turn over this page until you are told to do so.
2. Follow all instructions carefully.
3. Answer all questions.
4. Shade your answers on the Optical Answer Sheet (OAS) provided.
5. This booklet consists of 27 printed pages and 1 blank page.

10  
11  
12  
13  
14  
15  
16  
17  
18  
19  
20  
21  
22  
23  
24  
25  
26  
27  
28  
29  
30  
31  
32  
33  
34  
35  
36  
37  
38  
39  
40  
41  
42  
43  
44  
45  
46  
47  
48  
49  
50  
51  
52  
53  
54  
55  
56  
57  
58  
59  
60  
61  
62  
63  
64  
65  
66  
67  
68  
69  
70  
71  
72  
73  
74  
75  
76  
77  
78  
79  
80  
81  
82  
83  
84  
85  
86  
87  
88  
89  
90  
91  
92  
93  
94  
95  
96  
97  
98  
99  
100

For each question from 1 to 28, four options are given. One of them is the correct answer. Make your choice (1, 2, 3 or 4). Shade your answer on the Optical Answer Sheet (OAS).

(56 marks)

1 Study the classification table below carefully.

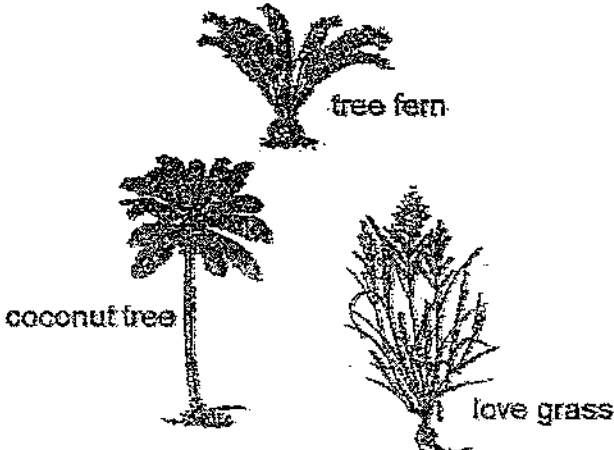
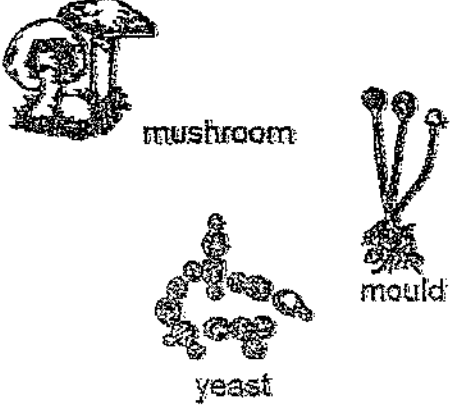
Group X	Group Y
 <p>free fern</p> <p>coconut tree</p> <p>love grass</p>	 <p>mushroom</p> <p>yeast</p> <p>mould</p>

Which of the following statement(s) is/are correct?

- A The organisms in Group X and Group Y are non-flowering plants.
- B The organisms in Group X and Group Y are reproduced by spores.
- C The organisms in Group X contain chlorophyll but not those in Group Y.
- D The organisms in Group Y are micro-organisms but not those in Group X.

- (1) C only
- (2) A and B only
- (3) C and D only
- (4) A, B and D only

(Go on to the next page)

- 2 The diagram below shows the human digestive system.

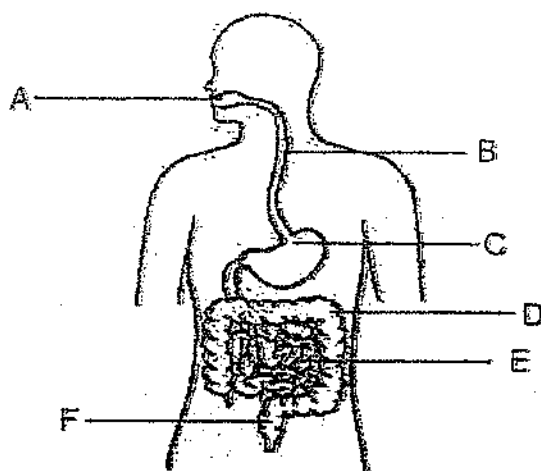

The chart below shows how the organs of the human digestive system are classified.

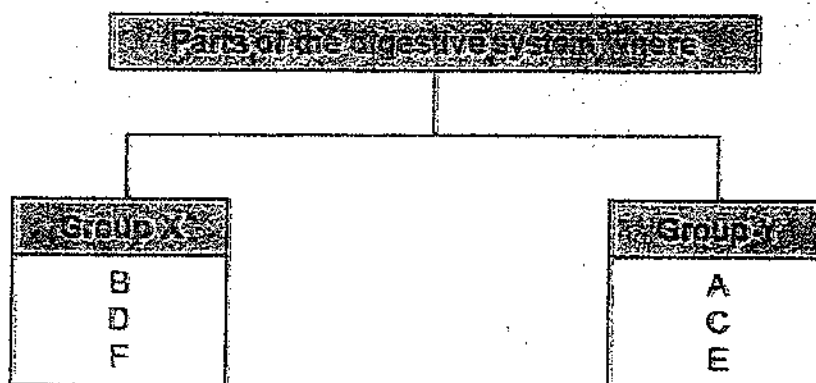

Based on the diagram and the classification chart above, which one of the following shows the correct heading for group Y?

- (1) Digestion is completed.
- (2) Digestive juices are produced.
- (3) Absorption of water takes place.
- (4) Absorption of digested food takes place.

(Go on to the next page)

- 3 Marcus cut two rings of different thickness, part A and part B, from a stem and removed them from a plant as shown below.

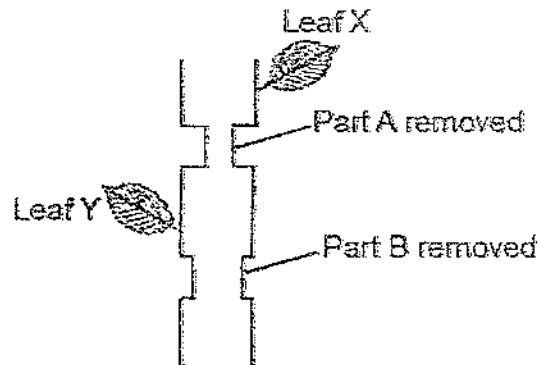

He recorded his observation of leaves X and Y after one week in the table below.

Leaf	Observation
X	It turned brown and wilted.
Y	It remained green and healthy.

Which one of the following options correctly shows the parts that were removed?

	Part A	Part B
(1)	Food-carrying and water-carrying tubes	Water-carrying tubes only
(2)	Food-carrying tubes only	Food-carrying and water-carrying tubes
(3)	Water-carrying tubes only	Food-carrying and water-carrying tubes
(4)	Food-carrying and water-carrying tubes	Food-carrying tubes only

(Go on to the next page)

- 4 Mary wanted to conduct an experiment to find out if the colour of petals has an effect on the number of pollinators attracted to the flower. She has the following flowers as shown in the table below.

Flower	Colour of petals	Characteristics
A	red	anther within the flower
B	white	anther within the flower
C	yellow	large petals
D	white	sweet scent
E	pink	no scent
F	white	small petals

Which of the flowers should Mary compare to conduct her experiment?

- (1) A and B only
- (2) D and E only
- (3) B, D and F only
- (4) C, E and F only

(Go on to the next page)

- 5 The diagrams below show the female and male reproductive systems.

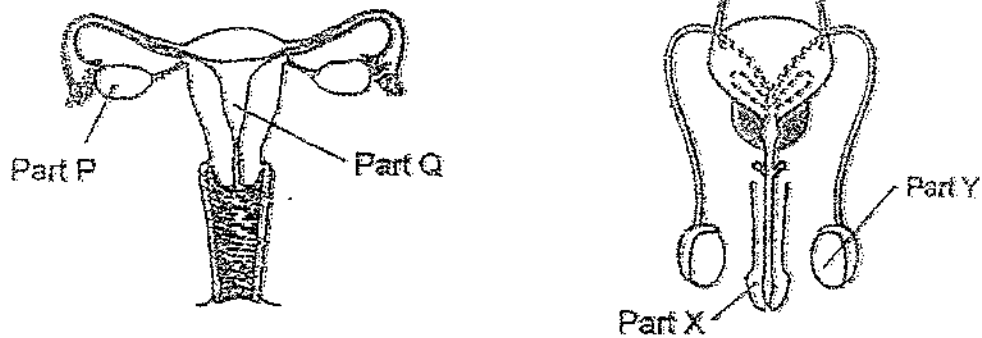

In which parts of the reproductive systems are the reproductive cells produced?

- (1) Q and X only
  - (2) P and X only
  - (3) P and Y only
  - (4) Q and Y only
- 6 The diagram below shows the cross-section of a flower.

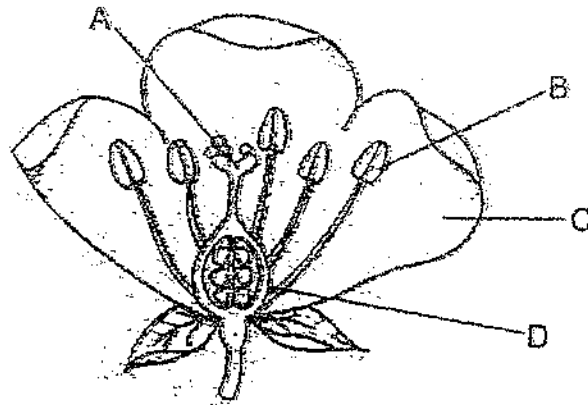

Which of the following statements are correct?

- A: Part D will develop into a fruit after fertilisation.  
 B: This flower is likely to be an insect-pollinated flower.  
 C: During pollination, pollen will be transferred from Part A to Part B.  
 D: Before pollination takes place, if Parts B and C are removed, the flower will still be able to turn into a fruit.
- (1) A and C only
  - (2) B and D only
  - (3) A, B and D only
  - (4) B, C and D only

(Go on to the next page)

- 7 A tightly sealed plastic bag containing substance Y is placed into a beaker containing substance Z. After 5 minutes, some substance Z was found inside the plastic bag as shown below.

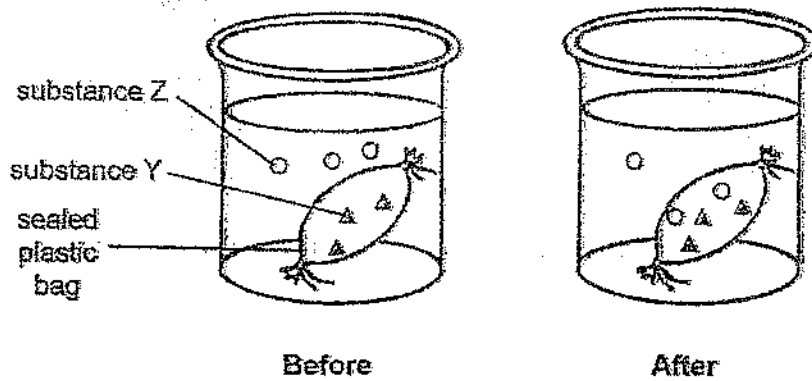

Based on this observation, which part of a cell has a similar function as the plastic bag shown above?

- (1) cell wall
- (2) cytoplasm
- (3) chloroplast
- (4) cell membrane

(Go on to the next page)



- 8 The diagram below shows how blood flows in some parts of the human body a few hours after a meal.

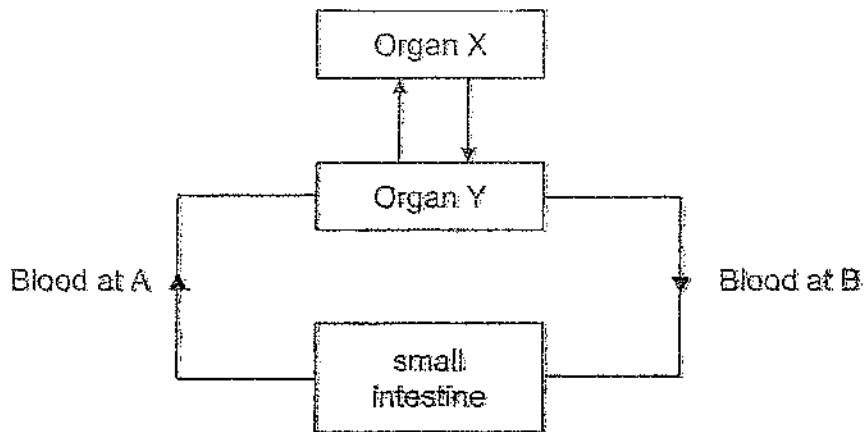

Which of the following below best describes the diagram above?

	Organ X	Organ Y	Blood at A compared to blood at B
(1)	lungs	heart	more digested food and more carbon dioxide
(2)	lungs	heart	less digested food but more carbon dioxide
(3)	heart	lungs	less digested food and less carbon dioxide
(4)	heart	lungs	more digested food but less carbon dioxide

(Go on to the next page)

- 9 Three children were comparing the movement of substances in a plant transport system and the human circulatory system.

The human circulatory system has the heart which pumps blood all around the body but the plant transport system does not have any organ to pump substances around the plant.



Peter

The blood in the human circulatory system and the parts of the plant transport system both carry air, food and water all around the human body and the plant respectively.



Queenie

Just as the blood flows from the lungs to the heart and then back to the lungs again, water from the roots is transported to all parts of the plant and then back to the roots again.



Rick

Which of the three children made the correct statements?

- (1) Peter only
- (2) Peter and Rick only
- (3) Queenie and Rick only
- (4) Peter, Queenie and Rick

(Go on to the next page)

- 10 Jalen measured the amount of light, oxygen and the temperature in a field on a sunny day. He plotted three graphs to show the changes in the amount of light, oxygen and temperature from 7am to 12 noon.

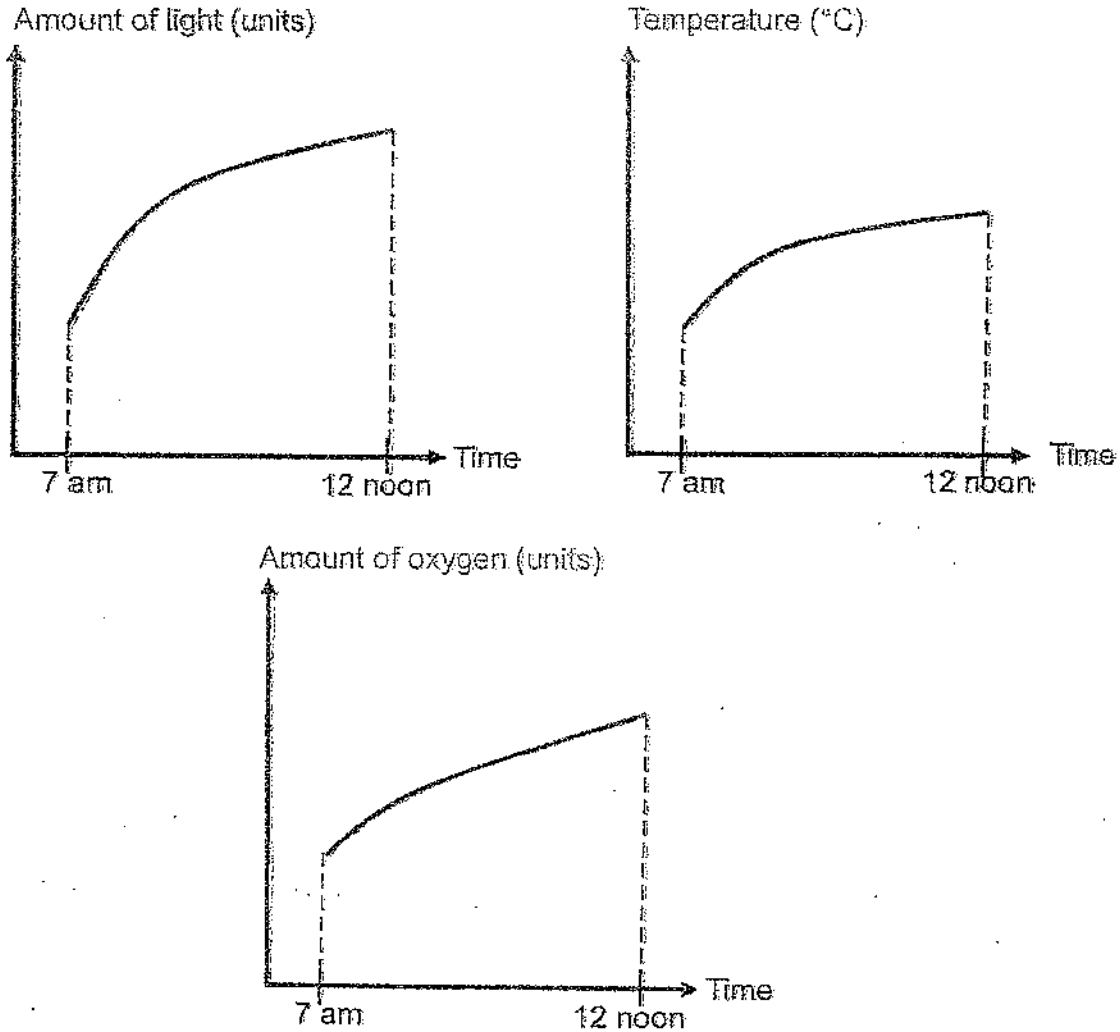

Based on the graphs above, what could have caused the amount of oxygen to increase from 7am to 12 noon?

- (1) All living things produce oxygen during daytime.
- (2) Plants do not take in oxygen when the amount of light increases.
- (3) Animals give off more oxygen when the surrounding temperature increases.
- (4) The rate of photosynthesis increases due to an increase in the amount of light.

(Go on to the next page)

- 11 A group of students recorded the number of organisms found in their school's pond. They drew the bar chart shown below based on the data they had collected.

Number of organisms

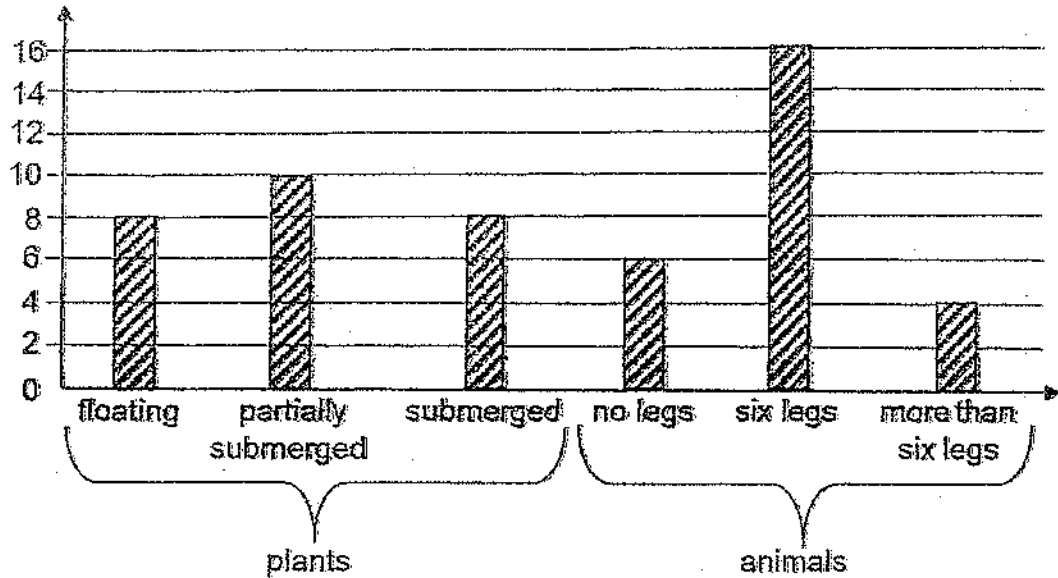

Which of the following statements about the organisms in the pond are true?

- A: There are 26 populations of plants.  
 B: There are at least 6 populations of plants and animals.  
 C: The number of floating and submerged plants are equal.  
 D: Insects are greater in number than any other group of animals.

- (1) A and C only  
 (2) B and D only  
 (3) B, C and D only  
 (4) A, B, C and D

(Go on to the next page)

- 12 The chart below shows how a human activity can have negative effects on the environment.

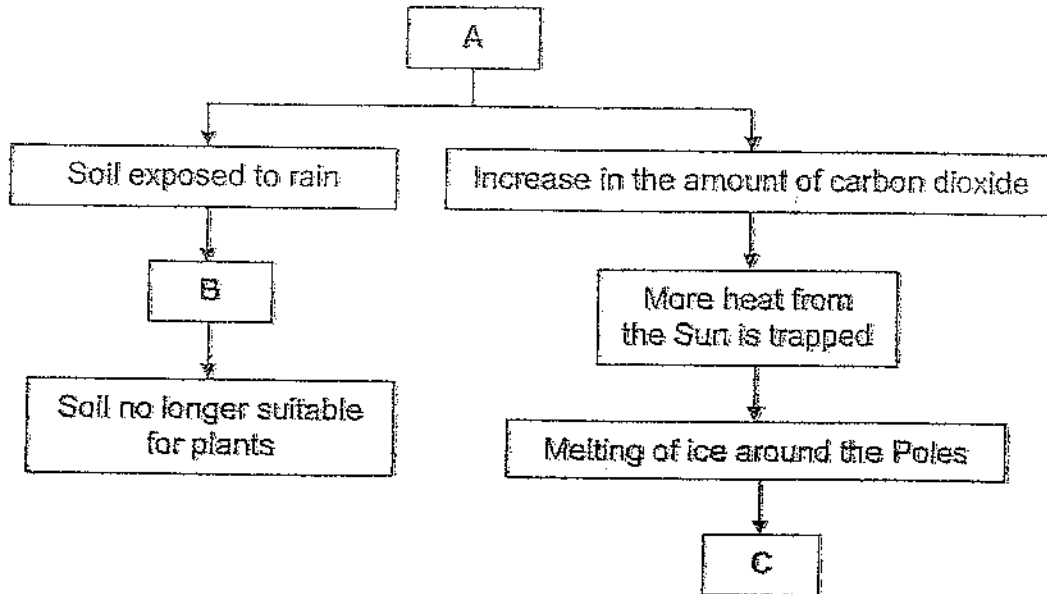

Which of the following best represents A, B and C?

	A	B	C
(1)	Deforestation	Soil erosion	Draught
(2)	Deforestation	Soil erosion	Rise in sea level
(3)	Burning fossil fuels	Flooding	Haze
(4)	Burning fossil fuels	Haze	Flooding

(Go on to the next page)

- 13 Meng Zhe observed two organisms, X and Y. Organism X has an air bubble attached to its body and organism Y has a breathing tube.

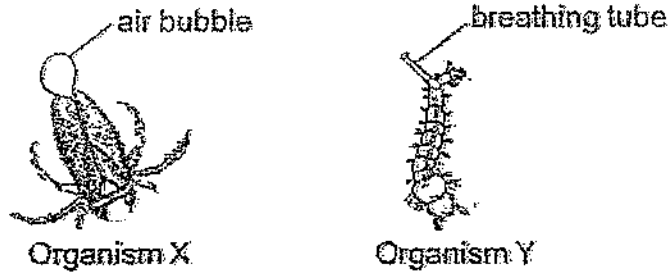

Which one of the following most likely shows where Meng Zhe found the two organisms?

	Organism X	Organism Y
(1)	On plants above the pond	Just under the surface of the pond
(2)	Just under the surface of the pond	At the bottom of the pond
(3)	At the bottom of the pond	Just under the surface of the pond
(4)	At the bottom of the pond	On plants above the pond

- 14 Which of the following activities do not harm the environment?

- A: Writing on both sides of the paper before recycling it.
- B: Turning off the lights in a room when no one is inside.
- C: Driving to work by car instead of taking public transport.
- D: Bringing your own recyclable bag when you go grocery shopping.

- (1) A and C only
- (2) B and D only
- (3) A, B and C only
- (4) A, B and D only

(Go on to the next page)

- 15 Azriyan set up an experiment as shown below to compare the flexibility of four strips made of different materials, P, Q, R and S, respectively.

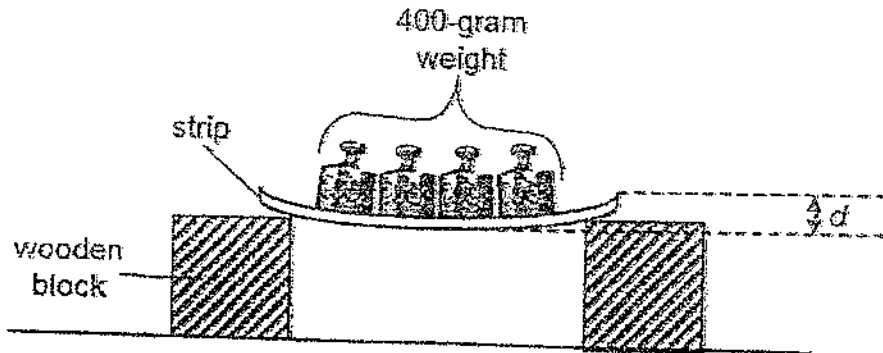

On each strip, he placed a 400 g weight. He then measured the distance,  $d$ , between the highest and lowest points of the strip.

The results of his investigation are shown in the table below.

Strip	$d$ (mm)
P	13
Q	2
R	25
S	8

Based on the results of Azriyan's investigation, which materials are the most suitable to make parts X and Y of the object shown below respectively?



	Material for X	Material for Y
(1)	Q	R
(2)	Q	S
(3)	P	S
(4)	R	Q

(Go on to the next page)

- 16 Dinesh hung four metal bars, J, K, L and M, from horizontal rods as shown below.

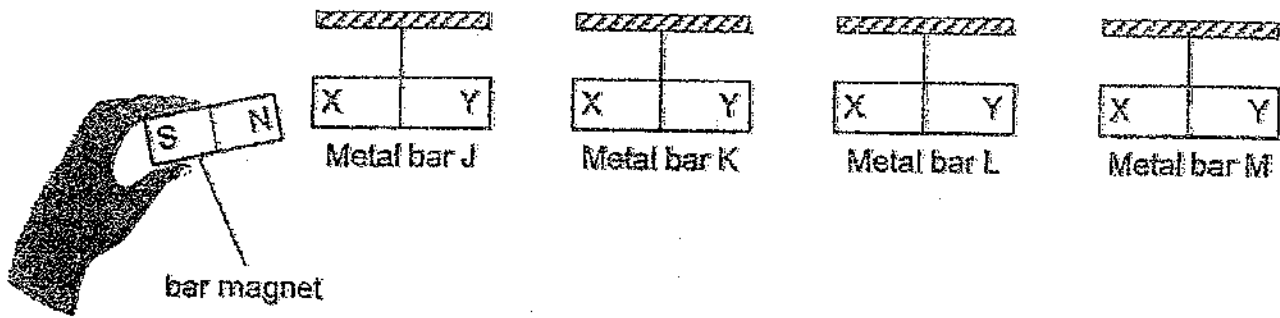

He then brought the north pole of a bar magnet near end X and later near end Y of each metal bar.

He recorded his observations in the table below.

Metal bar	Observations	
	North pole and end X of metal bar	North pole and end Y of metal bar
J	attracted	attracted
K	attracted	repelled
L	no reaction	no reaction
M	repelled	attracted

He wrote the following statements after conducting the experiment.

- A: Metal bar K is made of a magnetic material.  
 B: Metal bar L can make a compass needle move.  
 C: End X of metal bar K will repel end X of metal bar M.  
 D: Both ends of metal bar M will attract metal bar J.

Which of the above statements are not correct?

- (1) A and D only  
 (2) B and C only  
 (3) B, C and D only  
 (4) A, B and D only

(Go on to the next page)



- 17 The picture below shows the burning of some wood.



Which one of the following correctly shows the conversion of energy during the burning of wood?

- (1) Potential energy  $\rightarrow$  light energy
- (2) Potential energy  $\rightarrow$  heat and light energy
- (3) Potential energy  $\rightarrow$  kinetic energy  $\rightarrow$  heat energy
- (4) Heat energy  $\rightarrow$  light energy  $\rightarrow$  potential energy

(Go on to the next page)

- 18 The table below indicates the state of substances P, Q and R at different temperatures.

Substance	State of substance at the different temperatures		
	30°C	60°C	100°C
P	liquid	liquid	gas
Q	liquid	gas	gas
R	solid	solid	solid

Based on the information above, which one of the following statements is correct?

- (1) Substance P has the highest boiling point.
- (2) Substance R has the highest melting point.
- (3) Substance P has the same melting point as substance Q.
- (4) Substance Q has a higher melting point than substance R.

(Go on to the next page)

- 19 A metal box containing  $400 \text{ cm}^3$  of air was placed on an electronic weighing scale as shown in the diagram below.

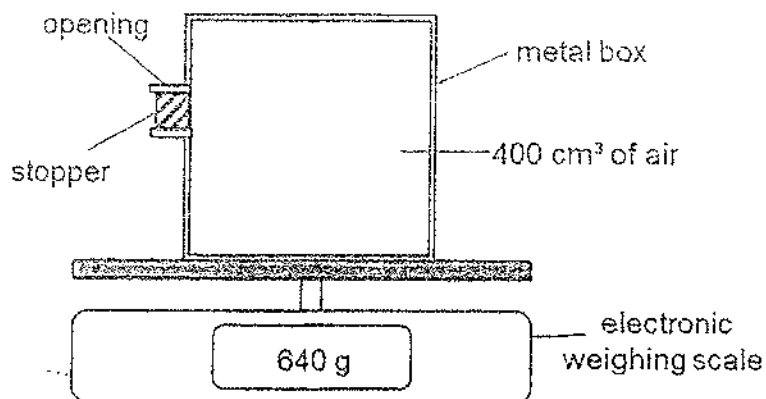

$150 \text{ cm}^3$  more air was pumped into the metal box through the opening.

Which one of the following correctly shows the volume of air in the metal box and the reading on the electronic weighing scale?

	Volume of air in the metal box ( $\text{cm}^3$ )	Reading on the electronic weighing scale (g)
(1)	400	640
(2)	400	More than 640
(3)	550	640
(4)	550	More than 640

(Go on to the next page)

- 20 Max carried out an experiment using a torch, a tennis ball and a screen as shown below.

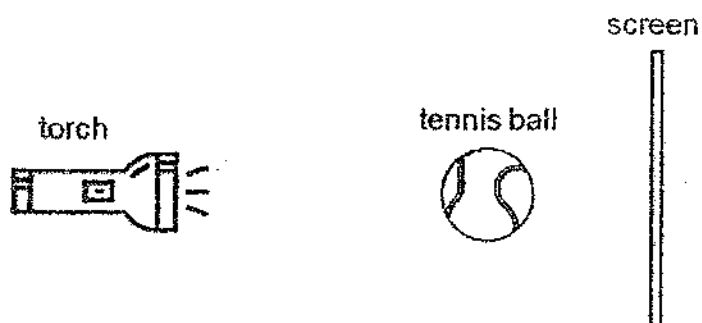

He wrote down what he did below:

**Steps:**

I.	Switch on the torch.
II.	Measure the height of the tennis ball's shadow formed on the screen.
III.	Move the tennis ball 3 cm closer to the torch.
IV.	Measure the height of the tennis ball's shadow again.
V.	Repeat steps (III) and (IV) two more times, each time moving the tennis ball 3 cm closer to the torch.

Which one of the following is the correct hypothesis for his experiment?

- (1) The size of the torch will affect the size of the shadow.
- (2) The colour of the tennis ball will affect the sharpness of the shadow.
- (3) The distance between the torch and the tennis ball will affect the shape of the shadow.
- (4) The distance between the torch and the tennis ball will affect the height of the shadow.

(Go on to the next page)

21 Study the diagram below.

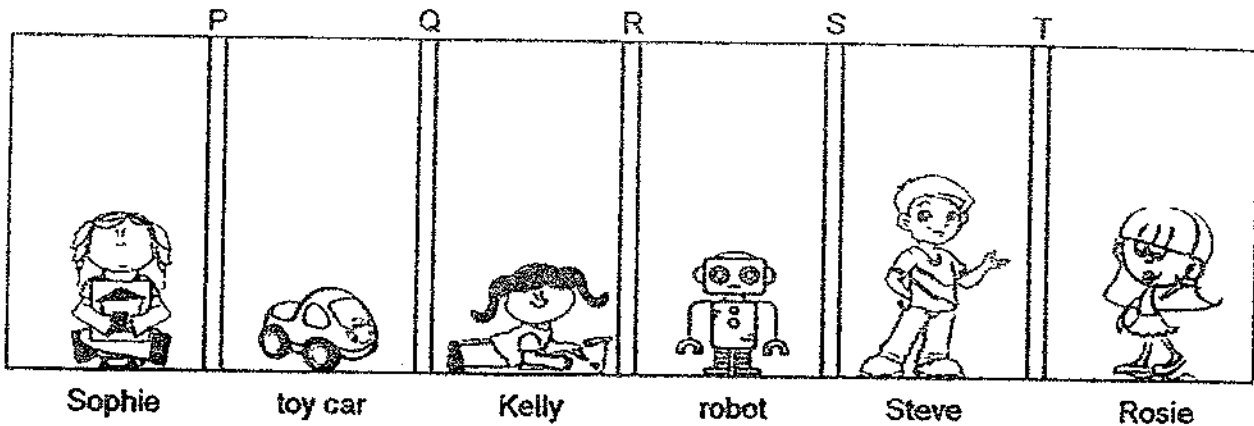

Four children and two of their toys are separated by screens, P, Q, R, S and T. The screens are made of different materials.

- Sophie is unable to see Kelly.
- Both Rosie and Steve are unable to see the robot.
- Kelly can see both the toy car and the robot clearly.

Based on the information given above, which one of the following could be the materials used to make the screens?

	P	Q	R	S	T
(1)	Clear plastic	Wood	Clear plastic	Rubber	Clear glass
(2)	Wood	Rubber	Rubber	Clear plastic	Clear glass
(3)	Clear plastic	Clear glass	Wood	Rubber	Clear glass
(4)	Rubber	Clear plastic	Clear glass	Wood	Clear plastic

(Go on to the next page)



22 Jerry set up an experiment as shown below.

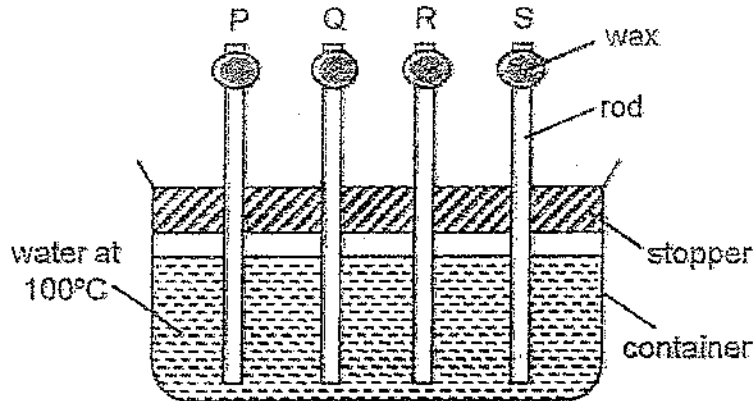

Rods P, Q, R and S are equal in size and made of different materials. He placed the same amount of wax on the tip of each rod and placed the rods in a container of boiling water. Jerry measured and recorded the time taken for all the wax on each rod, P, Q, R and S to melt. He plotted his results in a bar graph as shown below.

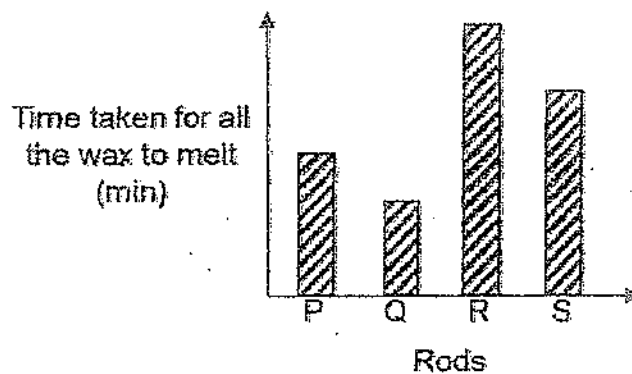

Which one of the rods is made of a material that is most suitable for making a container to store ice cubes so that the ice cubes will take the longest time to melt?

- (1) Rod P
- (2) Rod Q
- (3) Rod R
- (4) Rod S

(Go on to the next page)

- 23 Jane poured equal volumes of water from two beakers of water, P and Q, into an empty container.

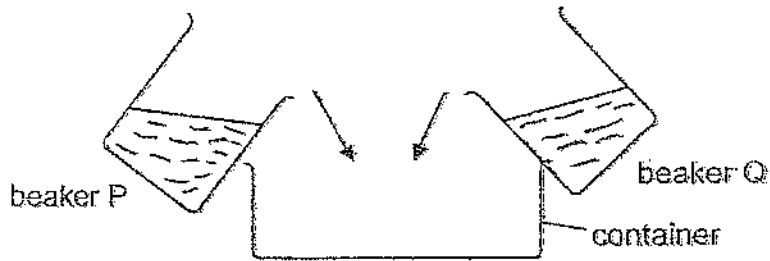

The final temperature of water in the container was  $45^{\circ}\text{C}$ .

Which of the following best represents the temperature of the water in each of the beakers just before pouring into the container?

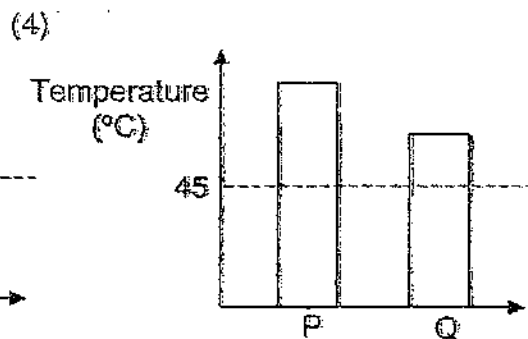
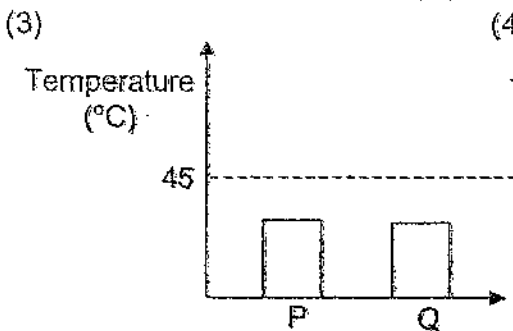
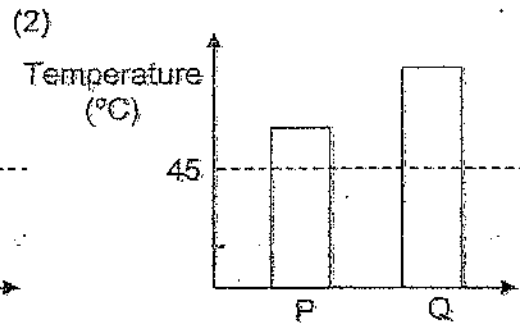
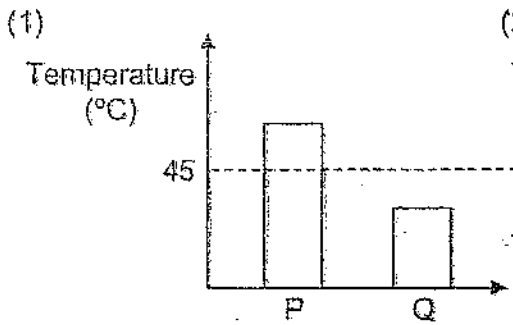

(Go on to the next page)



- 24 The diagram below represents the water cycle. X and Y are processes that occur in the water cycle.

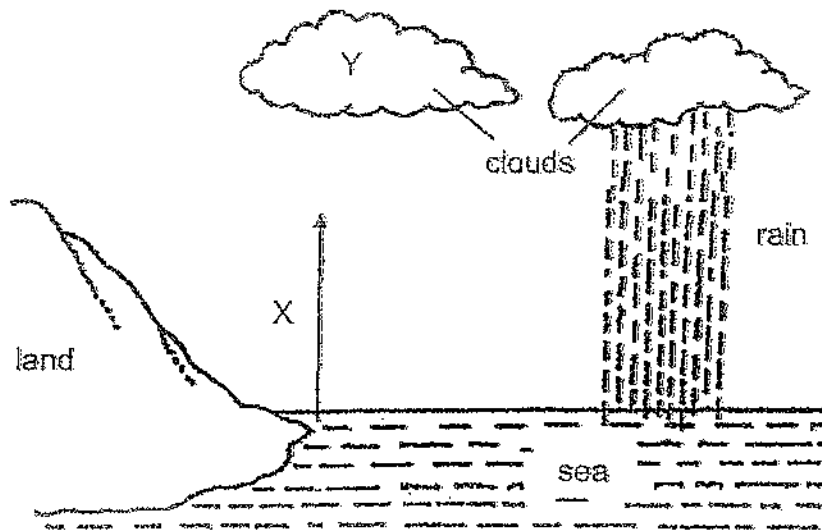

Which of the following statements about the water cycle is correct?

- (1) Y involves a gain of heat.
- (2) X takes place when water condenses.
- (3) X takes place when water evaporates.
- (4) Y takes place when water vapour evaporates.

(Go on to the next page)

- 25 Grace set up an electrical circuit as shown below. All electrical parts are in good working conditions.

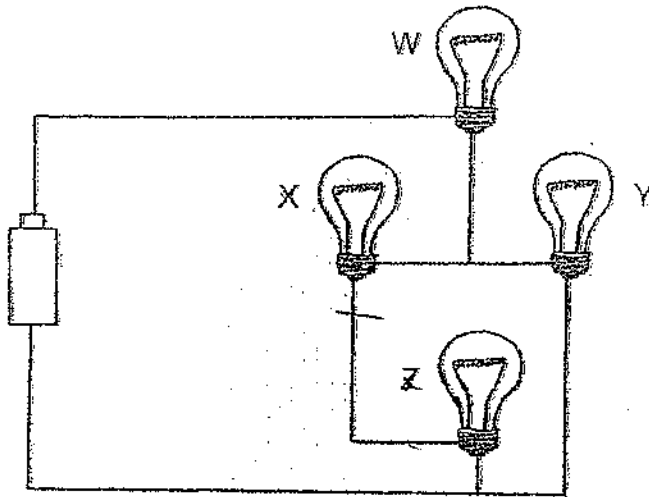

Which bulbs will remain lit when bulb X fuses?

- (1) W and Y only
- (2) W and Z only
- (3) Y and Z only
- (4) W, Y and Z only

(Go on to the next page)

- 26 A stationary holder with a magnet in it was attracted to a whiteboard made of magnetic material. Some markers were then added to the holder and the holder started to slide down while still being attracted to the whiteboard as shown in the diagram below.

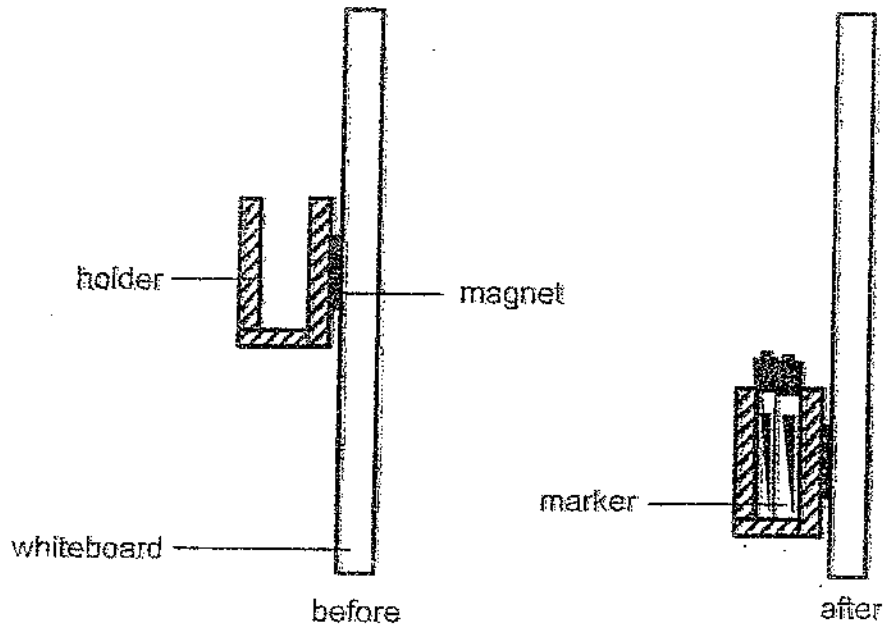

Which one of the following statements explains this observation?

- (1) The magnetic force of the magnet is less than the weight of the holder and markers.
- (2) The magnetic force of the magnet is greater than the weight of the holder and markers.
- (3) The friction between the magnet and the whiteboard is less than the weight of the holder and markers.
- (4) The friction between the magnet and the whiteboard and the magnetic force of the magnet is less than the weight of the holder and markers.

(Go on to the next page)

- 27 A spring was attached to a wall and block Y was attached to the spring and left to rest. A magnet was then brought near block Y as shown in the diagram below.

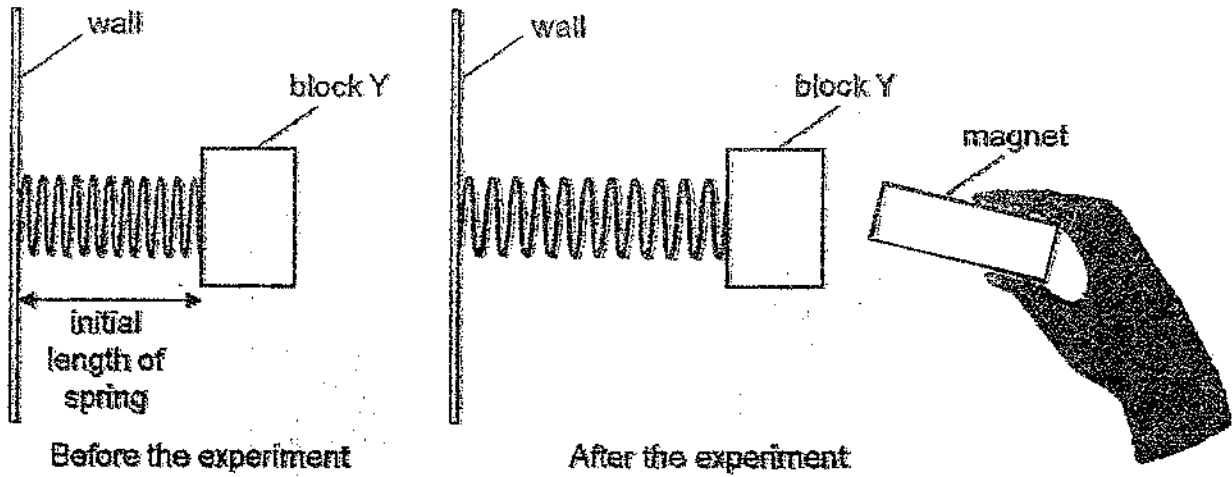

Which of the following forces are acting on block Y at the end of the experiment?

- A: Gravitational force
- B: Magnetic force
- C: Elastic spring force

- (1) A and C only
- (2) A and B only
- (3) B and C only
- (4) A, B and C

(Go on to the next page)

- 28 A tennis player hit a tennis ball and it followed a path of movement as shown by the dotted line shown in the diagram below.

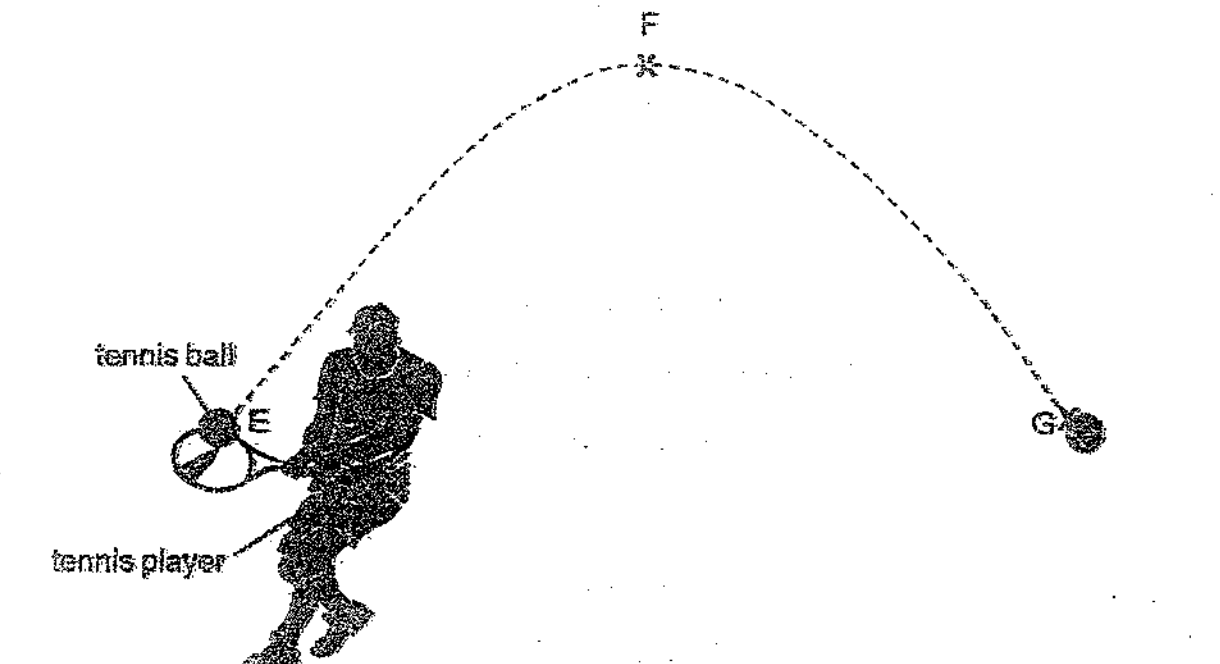

Which of the following statements below are correct?

- A: The tennis ball stopped moving at point G.
- B: The tennis ball's speed increased from point F to point G.
- C: The tennis ball has the greatest gravitational potential energy at point F.
- D: Gravitational force acting on the tennis ball is higher at point F than point E.

- (1) A and C only
- (2) B and C only
- (3) B, C and D only
- (4) A, B, C and D

**End of Booklet A**

(Go on to Booklet B)



**Temasek Primary School**  
**Preliminary Examination**  
**Primary Six Standard**  
**2023**  
**SCIENCE**  
**(BOOKLET B)**

Name: \_\_\_\_\_ ( )                      Class: 6 ( )

Date : 24 August 2023

Total Time for Booklets A and B: 1 hour 45 minutes

**INSTRUCTIONS TO CANDIDATES**

1. Do not turn over this page until you are told to do so.
2. Follow all instructions carefully.
3. Answer all questions.
4. Write your answers in this booklet.
5. This booklet consists of 17 printed pages and 1 blank page.

Paper	Max Mark	Score
Booklet A	56	
Booklet B	44	
Total Mark	100	

Parent's Signature/Date: \_\_\_\_\_

For each question from 29 to 40, write your answers in the spaces provided. The marks allocated to each question are indicated in the brackets. (44 marks)

29 The food chain below shows the food relationship among three organisms, X, Y and Z.

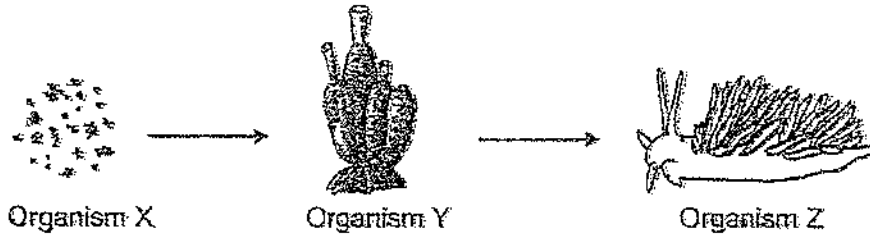

Organism Y can be found in water that is slightly further away from the seashore. It has only a few types of predators as it is poisonous.

The diagram below shows how organisms Y and Q depend on each other. Organism Q attaches pieces of Organism Y onto itself.

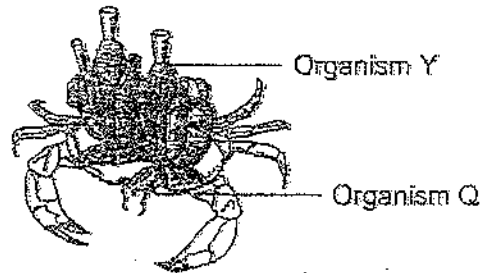

(a) State what is an organism. [1]

\_\_\_\_\_

(b) Based on the information above, state how Organism Y and Organism Q benefit from each other. [2]

Benefit for Organism Y:

\_\_\_\_\_

\_\_\_\_\_

Benefit for Organism Q:

\_\_\_\_\_

\_\_\_\_\_

(Go on to the next page)

SCORE	3

- 30 Kenneth conducted an experiment to find out the effect of physical activity on his heart rate. He measured his heart rate immediately after doing different number of sit-ups. His results are shown in the table below.

Trial	Number of sit-ups done	Heart rate (beats per min)			
		1 <sup>st</sup> reading	2 <sup>nd</sup> reading	3 <sup>rd</sup> reading	Average
1	10	90	97	93	93
2	20	110	115	120	115
3	40	130	140	135	135

- (a) Kenneth rested for 20 minutes before starting every trial. Explain why this allows him to carry out a fair experiment. [1]

---

---

- (b) State and explain what happens to his heart rate when he does more sit-ups. [2]

---

---

---

---



- (c) After exercising, Kenneth was sweating. He went into an air-conditioned room to rest. The temperature of the room was  $19\text{ }^{\circ}\text{C}$ . While resting, he observed white mist forming above his body.

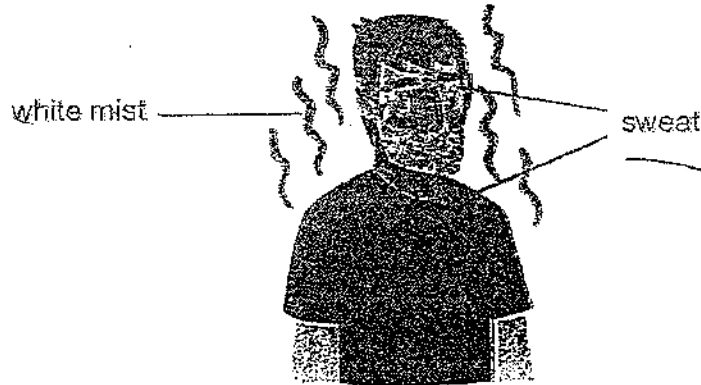

Explain how the white mist is formed.

[2]

---

---

---

---

(Go on to the next page)

SCORE	
	5

- 31 Julian wanted to find out how the cloudiness of river water affects the rate of photosynthesis in plants. He placed similar water plants and fish into three identical tanks P, Q and R which contained the same amount of water from different rivers P, Q and R respectively. The experiment was conducted in a dark room and a light source was placed near the tanks as shown below.

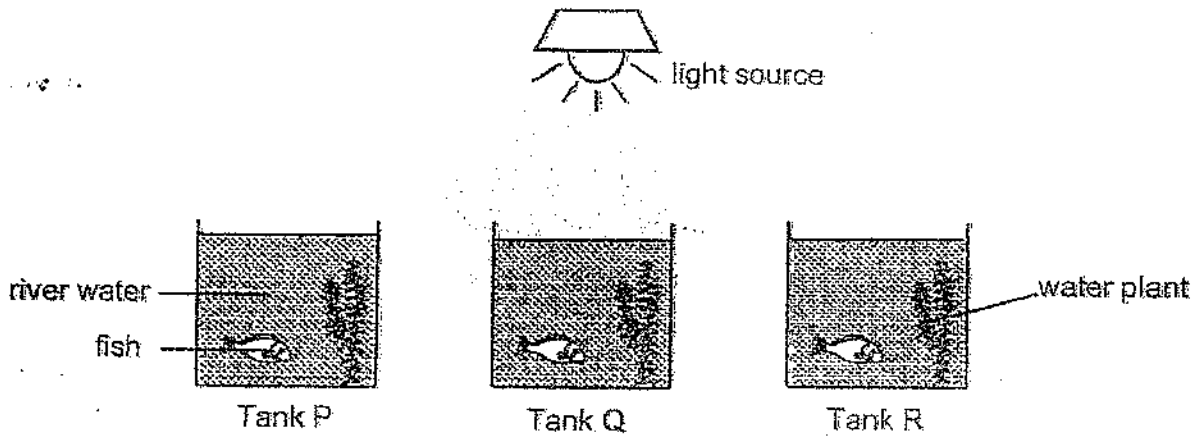

- (a) Julian added a fish to each tank. Explain his purpose of adding the fish. [1]

---



---

- (b) Julian's teacher commented that his experiment is not a fair test. Explain why. [1]

---



---

- (c) Julian did some changes to his set-up to make sure it was a fair test. He measured the amount of oxygen in the water of each tank and recorded the results in the table below.

Time	Amount of oxygen (units)		
	Tank P	Tank Q	Tank R
0 hour at start	5	5	5
1 hour later	19	13	21
4 hours later	27	20	36

Based on the results, Julian concluded that river Q was the least cloudy. Do you agree with his conclusion? Explain your answer. [1]

---

---

---

(Go on to the next page)

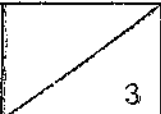
SCORE	
-------	---

- 32 Sam conducted an experiment to study the food relationships between animals Q, R and S. He placed some plant P and some animals Q and R into a box and counted the number of animals after each week. After three weeks, he added animal S into the box. The results are shown in the graph below.

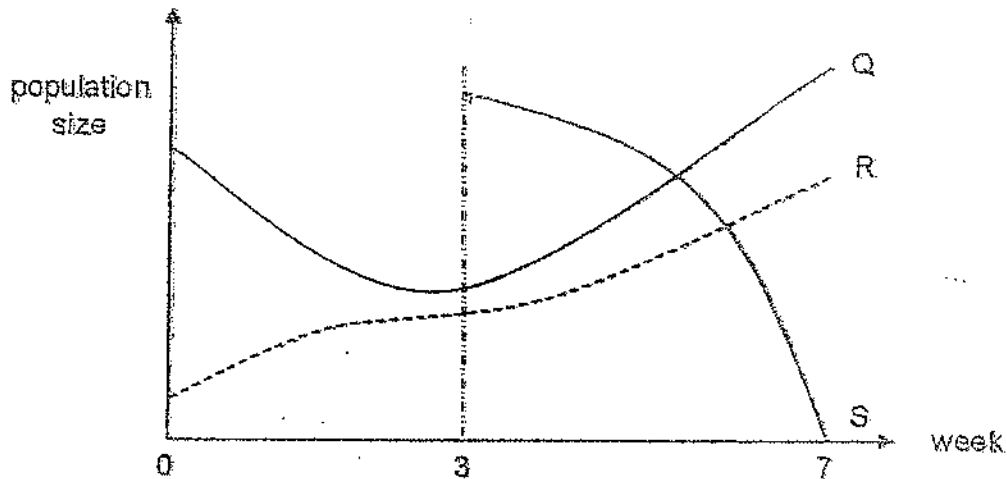

- (a) Complete the food chain below to show the food relationships between organisms P, Q and R. [1]

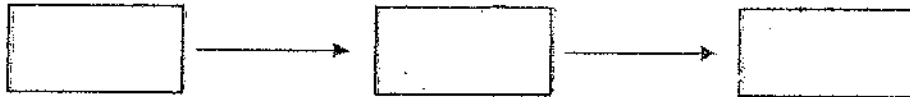

- (b) Complete the table below by writing P, Q, R and S in the table below. Each letter can be written more than once. [2]

Producer	Consumer	Prey	Predator

- (c) If no other animals are added into the box, explain what would happen to the population of Q after week 7. [1]

---



---

(Go on to the next page)

SCORE	4

33 The diagram below shows the fruits of Plant A. The fleshy fruits contained small hard seeds.



(a) Why do plants reproduce?

[1]

---



---

(b) A population of plant-eater, X, was introduced into the garden in week 4. It affected the area covered by plant A as shown in the graph below. Plant-eater X does not pollinate the flowers of plant A.

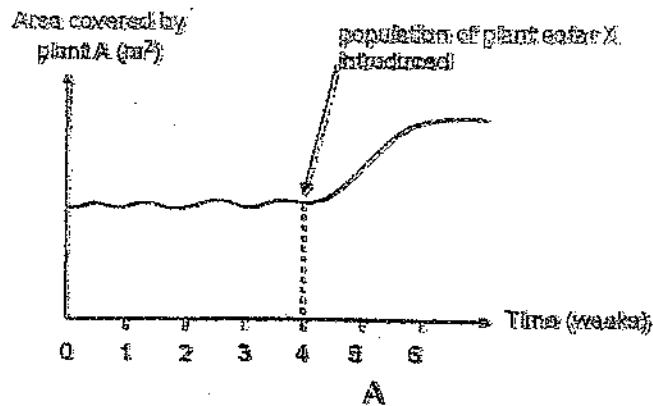

(i) State how the population of plant X changes from week 1 to week 6. [1]

---



---

(ii) Based on the information given, explain how the presence of the plant-eater X caused the area covered by Plant A to change. [2]

---



---



---

(Go on to the next page)

SCORE	
	4

34 Bird C lays its egg in another Bird W's nest. Bird C's egg looks like Bird W's egg.

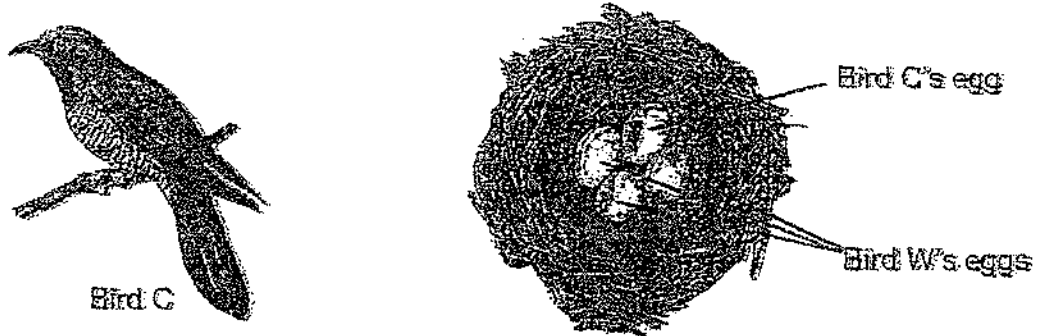

(a) Explain why it is beneficial for Bird C that its egg looks like the egg of Bird W. [1]

---



---

(b) Bird C's egg hatches first. The young will use its body to push the other eggs out of the nest when the adult bird is out looking for food.



State the type of adaptation above and explain how it benefits young of Bird C. [2]

---



---



---



---

(Go on to the next page)

SCORE	
	3

35 Carol placed three solids of the same size but made of different materials A, B and C into a container of water as shown.

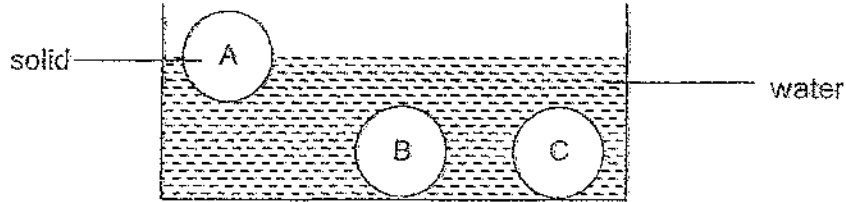

(a) From the diagram, state the physical property of balls B and C [1]

---

(b) Carol designed a device as shown to measure the amount of time that passed in hours. She filled container Z with water. When she removed the stopper from the holes, water flowed from container Z to container Y and from container Y to container X.

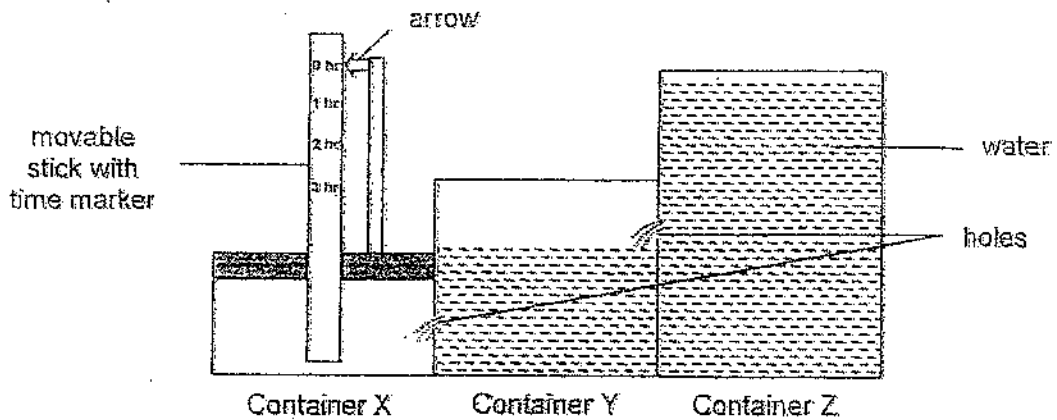

(i) Which material, A, B or C, should Carol use to make the stick? Explain how the material helps the device to measure the amount of time passed. [2]

---



---



---

(ii) Carol observed that the time indicated on the device was too fast. State one way how she can improve her set-up. [1]

---

(Go on to the next page)

SCORE	
	4

- 36 Four nails, P, Q, R and S, were tested to find out which makes the strongest magnet.

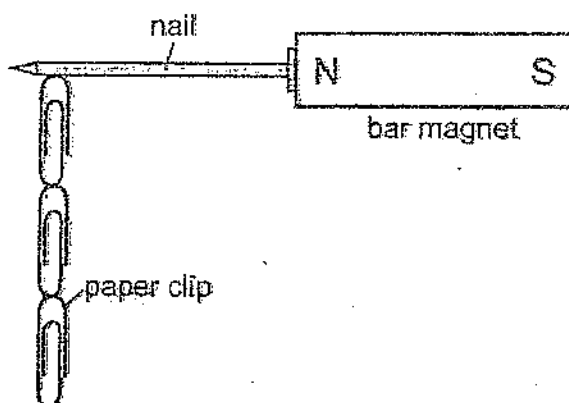

Each of the nails was placed against a bar magnet and the number of paper clips which the nail could attract was recorded as shown in the table below.

	nail			
	P	Q	R	S
Number of paper clips attracted to the nail	2	2	4	5

- (a) Other than the type of paper clips and length of the nails used, state one other variable that needs to be kept constant in the set-up. [1]

---

- (b) Based on the results of the investigation, which nail is the strongest magnet? Explain your answer. [1]

---



---

(Go on to the next page)

SCORE	
	2



37 Hakim bought a new toy. He could play with it as shown in the diagram below.

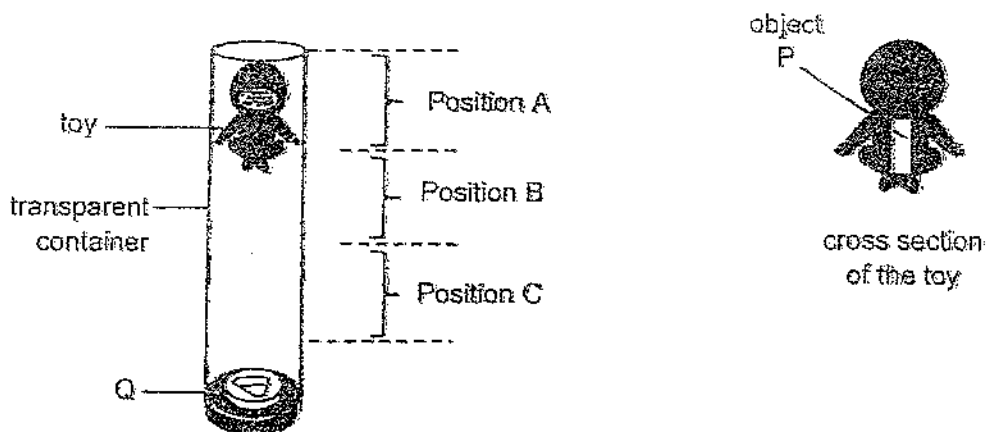

Object P is inside the toy. The toy is able to float at different positions A, B and C, by controlling the circuit that is connected to Q.

Hakim can close switches, S1, S2, S3, S4, S5 and S6, to control the circuit. This will change the position which the toy floats.

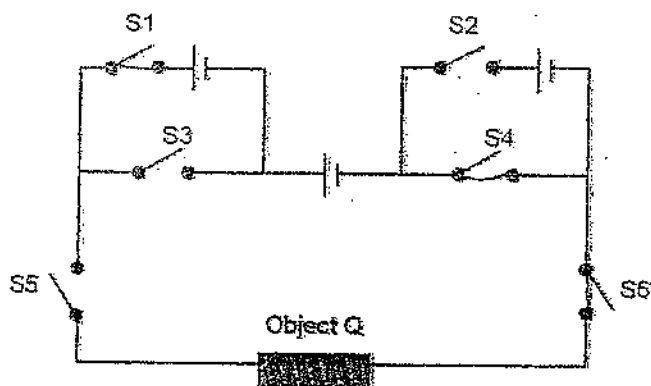

(a) In order for the toy to float at Position B, switches S1, S4, S5 and S6 have to be closed. Explain how the toy works to float at Position B. [2]

---



---



---



---

- (b) Which switch(es) does Hakim need to close so that Object P can float at Positions A and C? Make your choice by placing a tick in the appropriate boxes below. [2]

Position	Switches to be turned on					
	S1	S2	S3	S4	S5	S6
A						
B	✓			✓	✓	✓
C						

- (c) Using arrows, draw and label the forces acting on the toy when it is floating in the position as shown. [1]



(Go on to the next page)

SCORE	5
-------	---

38 Jack carried out an experiment as shown below. A temperature sensor connected to a datalogger was placed in the test tube in set-up A and the test tube in the middle of set-up B as shown below.

Each test tube contained the same volume of cold water at 10 °C.

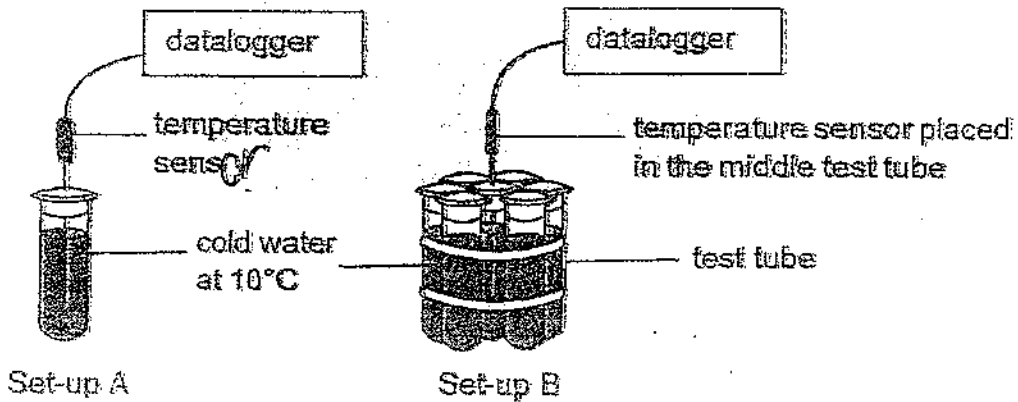

The graph below shows the changes of the temperatures of the water in the two test tubes.

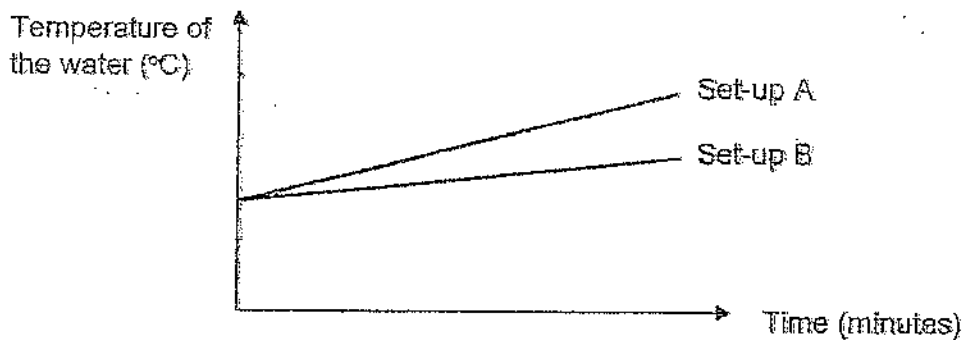

(a) Based on the results, what can Jack conclude about the heat transfer in the test tube in Set-up B as compared to the test tube in Set-up A? Explain your answer. [2]

---



---



---



---

- (b) The diagram below shows animals M huddling together in the cold, keeping their young in the middle.

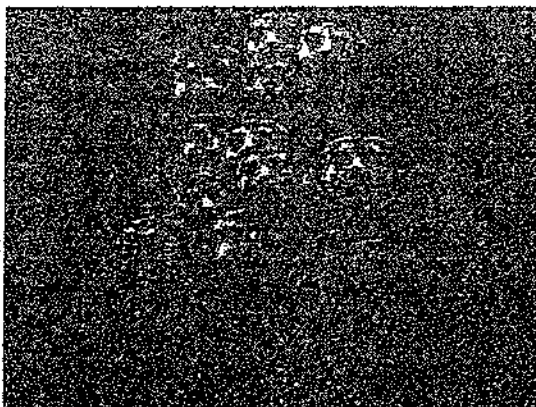

Based on the results of Jack's experiment, explain why it is an advantage for the animals to huddle together in the cold. [2]

---

---

---

---

(Go on to the next page)

SCORE	
	4

- 39 The Gravity Light is a project done by some students to provide light to places without electricity. It works by hanging weights which will pull the chain down. The chain will power a generator which will produce electricity that in turn will switch on the bulb.

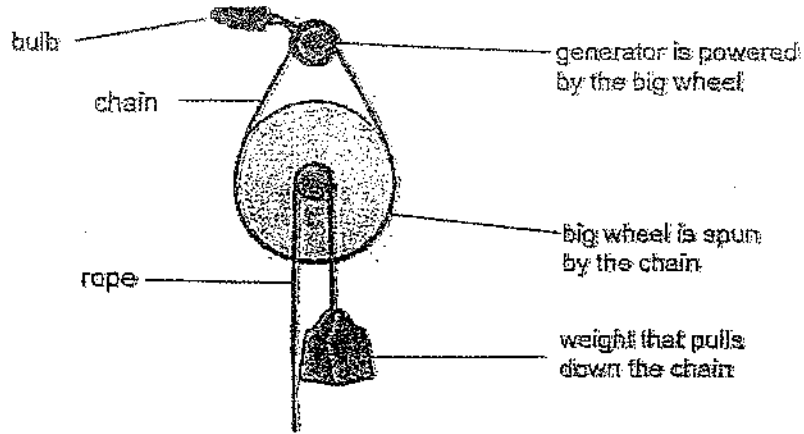

- (a) Fill in the boxes below to show the energy conversion in the Gravity Light. [1]

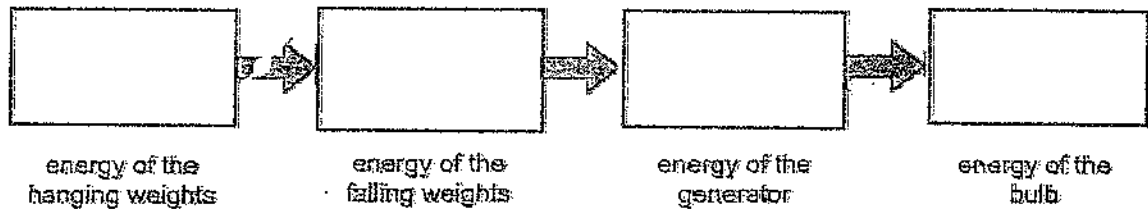

- (b) Without changing the wheel of the Gravity Light, how can the person using it make the bulb brighter? Explain your answer. [2]

---



---



---



---

(Go on to the next page)

SCORE	3
-------	---

40 James carried out an experiment by using various set-ups. He uses three types of springs P, Q and R. He compressed the spring to a length of  $d$  cm and placed a marble of mass  $m$  in front of it. When he released the spring, the marble moved up the slope. James measured the highest height  $h$  cm reached by the marble.

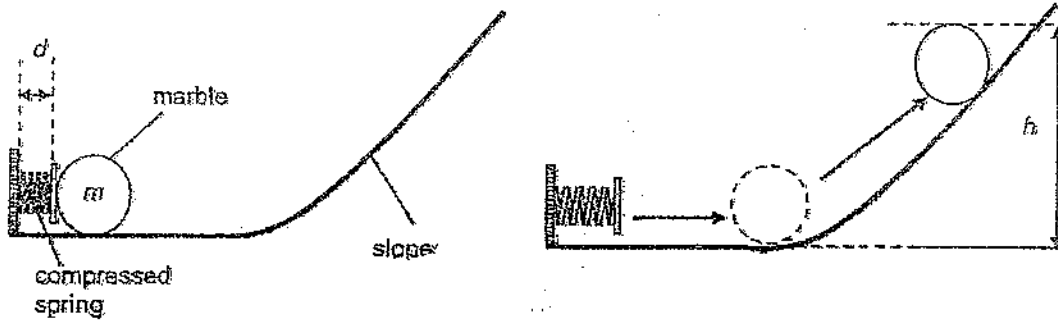

The table below shows the results obtained by varying the type of spring, distance  $d$  and mass  $m$ .

Set-up number	Type of spring	Distance $d$ (cm)	Mass $m$ (g)	Height $h$ (cm)
1	P	5	12	15
2	Q	8	14	23
3	R	5	14	18
4	P	5	10	18
5	Q	5	12	21
6	R	5	12	19

(a) Using the table above, state and explain which spring is the stiffest. [2]

---



---



---

(b) State the relationship between the mass of the marble and height  $h$ . [1]

---



---

(c) Explain your answer for (b) in terms of forces. [1]

---



---

End of paper.

SCORE	/
	4

EXAM PAPER 2023

LEVEL : PRIMARY 6  
 SCHOOL : TEMASEK PRIMARY SCHOOL  
 SUBJECT : SCIENCE  
 TERM : PRELIMINARY EXAMINATIONS

<b>Q1</b>	<b>Q2</b>	<b>Q3</b>	<b>Q4</b>	<b>Q5</b>	<b>Q6</b>	<b>Q7</b>	<b>Q8</b>	<b>Q9</b>	<b>Q10</b>
1	2	4	1	3	3	4	1	1	4
<b>Q11</b>	<b>Q12</b>	<b>Q13</b>	<b>Q14</b>	<b>Q15</b>	<b>Q16</b>	<b>Q17</b>	<b>Q18</b>	<b>Q19</b>	<b>Q20</b>
3	2	3	4	1	2	2	2	2	4
<b>Q21</b>	<b>Q22</b>	<b>Q23</b>	<b>Q24</b>	<b>Q25</b>	<b>Q26</b>	<b>Q27</b>	<b>Q28</b>		
4	3	1	3	1	3	4	2		

29	<p>a) An organism is a living thing or something which was living thing.</p> <p>b) Y gets protection from predators.</p> <p>c) Q will be protected from its predators as they will be poisoned by Y</p>
30	<p>a) When he rests, his heart rate will slow down to normal rate so he can get more accurate results.</p> <p>b) His heart rate will increase. During exercise more energy is needed. Heart needs to pump blood rich in oxygen and digested food faster.</p> <p>c) Water from the sweat gains heat from his body and evaporates into water vapour. The water vapour comes into contact with colder air, loses heat and condenses into tiny water droplets.</p>
31	<p>a) The fish will provide a direct / source of carbon dioxide for the plant to photosynthesis.</p>

b)	Tank Q is directly under the light and gets more light than P and R.
c)	No. Tank Q was the cloudiest. As the amount of oxygen released by the plant in Q is the lowest, the least amount of light must have reached the plant which resulted in the lowest rate of photosynthesis.

Q32	a)	P → Q → R			
	b)	<b>Producer</b>	<b>Consumer</b>	<b>Prey</b>	<b>Predator</b>
		P	Q, R, S	Q, S	R, Q
	c)	Population of Q will decrease, as there is no more S for Q to feed only.			
Q33	a)	Plants reproduce to continue their own kind.			
	b)	(i) The population of Plant A remains the same from week 1 to week 4, but increases from week 4 to week 6.			
		(ii) Plant-eater X feeds on the fruits of plant A. When X moves from place, the seeds are passed out in the droppings and germinate into new plants.			

Q34	a)	Bird C's egg will be cared for by Bird W until it hatches.
	b)	Behavioral adaptation. The young will get all the food from the adult with no competition.
Q35	a)	Sink in water.
	b)	(i) Material A, as it is able to float in water. As water flows into the container X, the movable stick moves upward and the arrow points to the time.  (ii) She could make a smaller hole in container Y and Z.

36	a) The magnet b) S. As S could attract the most paper clips out of the 4
----	---

37	a) When he closes S1, S4, S5, S6 the circuit is closed and object Q get turned into an electromagnet and can repel P. As the light poles are facing each other, they repel and push upwards.
----	--

b)

Position	Switches to be turned on					
	S1	S2	S3	S4	S5	S6
A	✓	✓	✓	✓	✓	✓
B	✓			✓	✓	✓
C	✓	✓	✓	✓	✓	✓

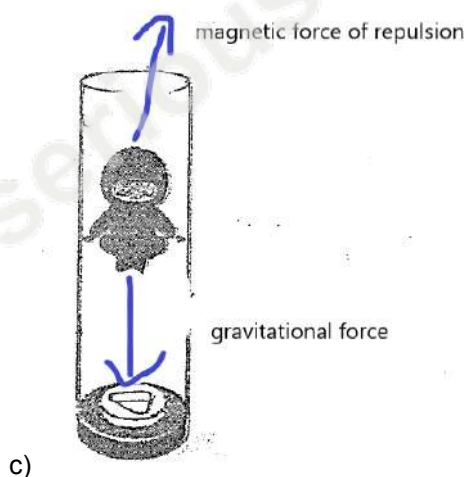



Q38	a)	Test tube in Set-up B gains heat slower than the test tube in set-up A. Test tube set-up B has less exposed surface area, thus will gain heat slower from the surroundings.
	b)	When animals huddle together, their bodies area will be less exposed to the surroundings, They will lose heat slower to the surroundings, keeping them warm.
Q39	a)	Gravitational Potential → kinetic → electrical energy → light
	b)	The person can add more weights to the set-up as when the heavier the weight is the more gravitational potential is converted to more kinetic energy which can be turned into more light energy.
Q40	a)	Spring Q is the stiffest. From Set-up 1, 5 and 6 height reached by the marble in set-up 5 is the highest. Spring Q has exerted the greatest amount of elastic spring force on the marble, thus pushing it he furthest.
	b)	The larger the mass of the marble the shorter the height.
	c)	For a larger mass, the friction between marble and ramp is greater, which slows down the marble more.